

**CITY OF GERING
CITY COUNCIL MEETING NOTICE AND AGENDA**

Regular meeting of the Gering City Council, May 11, 2026 at 6:00 p.m., at Gering City Hall, 1025 P Street, Gering, NE.

All agenda items are for discussion and action will be taken as deemed appropriate.

CALL TO ORDER.

1. Recital of the Pledge of Allegiance and Prayer
2. Roll Call
3. Excuse councilmember absence

OPEN MEETINGS ACT - NEB.REV.STAT. CHAPTER 84, ARTICLE 14

As required by State Law, public bodies shall make available at least one current copy of the Open Meetings Act posted in the meeting room. Agenda items may be moved up or down on the agenda at the discretion of the Mayor. As required by State Law, additions may not be made to this agenda less than 24 hours before the beginning of the meeting unless they are considered under this section of the agenda and Council determines that the matter requires emergency action.

CONSENT AGENDA:

(Items under the Consent Agenda are proposed for adoption by one action for all items unless any member of Council requests that an item be considered separately.)

1. Approve minutes of the April 27, 2026 regular City Council Meeting
2. Approve Claims

CURRENT BUSINESS:

1. Presentation of National Police Week Proclamation
2. Discussion regarding Safe Streets for All Grant Application
3. Consider approving Resolution 5-26-1 to adopt a target year for Vision Zero
4. Consider approving Keno Fund requests:
 - a. Stand Up and Play - Gering, NE Chapter, \$12,450
 - b. Allred Brothers Fireworks Show, \$8,500
 - c. Drive 308 Truck Show, \$2,500
 - d. PVC Monument Marathon, \$6,200
 - e. ESU 13, \$802.00
 - f. Scotts Bluff County CERT, \$2,818.16
 - g. Oregon Trail Days, \$4,100
 - h. Old West Balloon Fest, \$10,000
5. Consider moving the second regular City Council meeting in May to Tuesday, May 26 due to the Memorial Day holiday on Monday, May 25

BIDS/PROPOSALS:

1. Consider Substation Transformer Bid – Electric Department

CLOSED SESSION: (Council reserves the right to enter into closed session if deemed necessary.)

OPEN COMMENT: Discussion or action by Council regarding unscheduled business will not take place. This section is for citizen comment only.

ADJOURN

THE OFFICIAL PROCEEDINGS OF THE REGULAR MEETING OF THE GERING CITY COUNCIL, APRIL 27, 2026

A regular meeting of the City Council of Gering, Nebraska was held in open session on April 27, 2026 at 6:00 p.m. at Gering City Hall, 1025 P Street, Gering, NE. Present were Mayor Ewing and Councilmembers Shields, Gillen, Cecil, Kinsey, Wiedeman, O'Neal, Morrison, Jackson. Also present were City Administrator Pat Heath, City Clerk Kathy Welfl, and City Attorney Jim Ellison. All proceedings hereafter were taken while the meeting was open to the attendance of the public except as otherwise indicated.

CALL TO ORDER

Mayor Ewing called the meeting to order at 6:00 p.m. and stated that a quorum of the Council was present and City business could be conducted.

1. Recital of the Pledge of Allegiance and Prayer
2. Roll Call
3. Excuse Council Member absence (None)

OPEN MEETINGS ACT - NEB.REV.STAT. CHAPTER 84, ARTICLE 14

Mayor Ewing stated: As required by State Law, public bodies shall make available at least one current copy of the Open Meetings Act posted in the meeting room. Agenda items may be moved up or down on the agenda at the discretion of the Mayor. As required by State Law, additions may not be made to this agenda less than 24 hours before the beginning of the meeting unless they are considered under this section of the agenda and the Council determines that the matter requires emergency action.

CONSENT AGENDA:

(Items under the Consent Agenda are proposed for adoption by one action for all items unless any member of Council requests that an item be considered separately.)

1. Approve minutes of the April 13, 2026 regular City Council Meeting
2. Approve Claims
3. Approve March, 2026 Financial Report

CLAIMS 4-14-26 TO 4-28-26

24/7 FITNESS \$295.00, 308 PLUMBING SOLUTIONS \$475.00, ACCUSTAR SURVEYING \$2,500.00, ACE HARDWARE \$1,300.31, ACTION COMMUNICATIONS, INC. \$440.20, ACUSHNET COMPANY \$2,928.98, ADVANCED SERVICES, INC. \$567.20, AFLAC \$957.18, ALARM SECURITY TECHNICIANS \$38.95, AMAZON CAPITAL SERVICES \$1,091.28, AMERITAS LIFE INSURANCE CORP. \$622.84, ANDERSON & SHAW CONSTRUCTION \$19,358.10, AT&T MOBILITY \$1,044.60, BENZEL PEST CONTROL \$76.71, BIRD CONSERVANCY OF THE ROCKIES \$1,300.00, BLUFFS FACILITY SOLUTIONS \$220.41, BORDER STATES INDUSTRIES, INC \$5,099.74, CALLAWAY GOLF COMPANY \$527.35, CENGAGE LEARNING/GAGE \$30.75, CITY OF GERING \$740.52, COLUMN SOFTWARE, PBC \$28.36, CONTRACTORS MATERIALS, INC. \$1,014.00, CROELL, INC \$1,552.00, DANKO EMERGENCY EQUIPMENT CO \$211.08, DAVIS EQUIPMENT CORPORATION TURFWERKS \$1,849.75, DOOLEY OIL \$759.34, DUSTIN KINNAN \$265.00, DUTTON-LAINSON COMPANY \$5,173.84, EAKES INC \$209.82, ECOLAB \$409.40, ELITE TOTAL FITNESS \$165.00, FASTENAL COMPANY \$320.68, FEDEX \$197.76, FIRST NATIONAL BANK OF OMAHA \$12,466.53, FIRST NATIONAL BANK OMAHA - POLICE \$584.00, FLOYD'S TRUCK CENTER, INC. \$114.60, FRANCISCOS BUMPER TO BUMPER IN \$260.00, FRANK PARTS COMPANY \$(0.99), FRANKLIN SANTIAGO \$410.05, FRONTIER OVERHEAD DOOR \$3,123.06, GENERAL TRAFFIC CONTROLS, INC. \$309.00, GOLDSTAR PRODUCTS INC \$1,106.92, GREATAMERICA FINANCIAL SERVICE \$104.83, GT DISTRIBUTORS, INC. \$8,746.00, HDR ENGINEERING, INC. \$3,418.44, HOMETOWN LEASING \$164.55, HYDRO OPTIMIZATION & AUTOMATION \$1,913.34, IDEAL LAUNDRY AND CLEANERS, INC. \$494.43, INDEPENDENT PLUMBING & HEATING \$24.06, INDOFF INCORPORATED \$82.06, INTERNAL REVENUE SERVICE \$55,432.18, INTERSTATE BATTERY \$316.90, IRBY TOOL & SAFETY \$1,165.03, J & A TRAFFIC PRODUCTS \$1,654.20, J RODZ \$85.00, JACK'S UNIFORMS & EQUIPMENT \$266.25, JEO CONSULTING GROUP \$7,544.00, JIRDON AGRI CHEMICALS, INC \$672.00, JOHN HANCOCK USA \$20,583.50, JOHN HANCOCK USA FIRE \$1,075.74, JOHN HANCOCK USA POLICE \$11,213.24, JOHNSON CASHWAY CO. \$93.52, L.L. JOHNSON DISTRIBUTING \$356.40, LEAGUE ASSOC./RISK MANAGEMENT \$2,090.44, LEAGUE OF NE. MUNICIPALITIES \$476.00, LEGACY COOPERATIVE \$11,609.91, MAGPUL INDUSTRIES CORP \$591.30, MARK CHRISMAN TRUCKING \$3,030.00, MASEK DISTRIBUTING INC \$30.33, MB KEM OVERHEAD DOORS \$252.00, MENARDS \$1,160.10, MIDWEST CONNECT \$321.78, MOBIUS COMMUNICATIONS COMPANY \$30.00, MUNICIPAL ENERGY AGENCY OF NE \$330,580.20, MUNICIPAL SUPPLY, INC. OF NE. \$1,784.04, NC CHILD SUPPORT CENTRALIZED COLLECTIONS \$250.36, NEBRASKA CHILD SUPPORT PAYMENT CENTE \$714.93, NEBRASKA DEPARTMENT OF REV (PR) \$14,990.52, NEBRASKA DEPT OF REVENUE \$938.58, NEBRASKA DEPT. OF REVENUE \$64,803.33 ,NEBRASKA LAW ENFORCEMENT \$525.00 ,NEBRASKA PUBLIC HEALTH ENVIRO LAB \$105.00, NEBRASKA PUBLIC POWER DISTRICT \$2,598.87, NEBRASKA TRAVEL ASSOCIATION \$125.00, NKC TIRE \$1,773.31, NORTH PLATTE NRD \$67.00, NORTHWEST PIPE FITTINGS, INC \$2,981.37, OMAHA MAGAZINE, LTD \$695.00, O'REILLY AUTOMOTIVE STORE \$225.56, PANHANDLE ENVIRONMENTAL SERVICE, INC. \$736.00, PANHANDLE HUMANE SOCIETY \$3,168.50 ,PANHANDLE POWER SYSTEMS LLC \$135.00, PEACEFUL PRAIRIE NURSERY, INC \$118.97, PETE'S QUICK LUBE \$241.99, PH & S PRODUCTS, LLC \$292.00, PING INC \$790.98 ,PIPE WORKS PLUMBING LLC \$8,500.00 ,POMP'S TIRE SERVICE INC \$78.00 ,PT HOSE AND BEARING \$149.36, PVB VISA \$11,790.45 ,QUADIENT POSTAGE FUNDING \$20.90 ,RAPID FIRE PROTECTION \$1,380.00 ,REGIONAL CARE INC. \$1,973.13 ,REGIONAL WEST MEDICAL CENTER \$15.00, RIVERSTONEBANK \$646.70, RPM FITNESS \$110.00, RUSSELL'S EXCAVATION & CONSTRUCTION \$1,750.00 ,SANDBERG IMPLEMENT, INC. \$2,188.88, SARGENT DRILLING CO. \$2,694.38 ,SB/GERING LIONS CLUB \$10,000.00, SCB COUNTY REGISTER OF

DEEDS \$60.00, SCB. COUNTY AMBULANCE SERVICE \$316.23, SCOTTS BLUFF COUNTY COURT \$456.06, SCOTTSBLUFF-GERING UNITED WAY \$226.34, SCS ENGINEERS \$4,362.00, SENIOR CITIZENS CENTER \$1,500.00, SIMMONS OLSEN LAW FIRM, P.C. \$4,020.00, SIMON CONTRACTORS \$2,102.00, STRYKER SALES \$875.40, SWANNIES GOLF APPAREL CO \$2,262.96, TERESA TOSH \$17,603.15, TERRY CARPENTER, INC. \$650.00, THOMPSONGLASS,INC.\$200.00, TINA WORTHMAN \$154.00, TITAN MACHINERY INC. \$860.41, TOUR EDGE MFG INC \$719.00, TYLER TECHNOLOGIES \$3,342.50, UMCVB \$450.00, UNITED HEALTH CARE \$139,590.69, UTILITY BILL REFUNDS \$265.91, VALLEY AUTO LOCATORS LLC \$1,101.31, W J R INC. \$562.35, WESCO RECEIVABLES CORP. \$326.53, WESTERN COOPERATIVE COMPANY \$10,288.69, WESTERN PATHOLOGY CONSULTANTS \$344.00, WHITING SIGNS, LLC \$1,000.00, WYOMING FIRST AID & SAFETY \$295.81, YMCA OF SCOTTSBLUFF \$1,017.00, TOTAL CLAIMS \$870,032.50

Motion by Councilmember Gillen to approve the Consent Agenda. Second by Councilmember Morrison. There was no discussion. Mayor Ewing called for the vote. "AYES": Shields, Gillen, Cecil, Kinsey, Wiedeman, O'Neal, Morrison, Jackson. "NAYS": None. Abstaining: None. Absent: None. Motion carried.

CURRENT BUSINESS:

1. Future Agenda Item Request by Jay Sturdevant, Scotts Bluff National Monument Superintendent

Scotts Bluff National Monument Superintendent, Jay Sturdevant, addressed Council and stated that he has been at the park for a little over a year. He thanked Administrator Heath for helping him get his bearings in Gering, Tina Worthman for being a great resource, as well as Mike Davies and Jim Scott for their assistance with a water line issue. He also thanked the Gering Police Department for supporting their law enforcement division. He then invited the Council to come out to the park for a tour to show them what they're working on and what the next couple of years at the monument might look like.

2. Consider approving a Final Plat of Lot 1 & 2 Block 1, TJR Subdivision, a subdivision to the City of Gering, Scotts Bluff County, Nebraska - generally located at the northeast intersection of 10th Street and Lockwood Road

City Engineer, Annie Folck, stated that the City has received an application for a Final Plat for Lot 1 & 2, Block 1, TJR Subdivision, a subdivision to the City of Gering. Currently, the property consists of two separate parcels which are unplatted (they are tax lots), and are owned by the same person. The property owner would like to move the lot line in order to be able to sell a portion of one of the properties while retaining the remainder of the property and combining it with the adjacent parcel to the north. She showed the new lot lines on overhead screens and explained that both lots already have access to a developed street as well as access to all utilities. If the properties had been platted in the past, this could have been done administratively, but since they are unplatted, moving the lot line requires approvals from Planning Commission and City Council. The Planning Commission recommended approval at their meeting on April 7; staff recommends approval as well.

Motion by Councilmember Gillen to approve a Final Plat of Lot 1 & 2 Block 1, TJR Subdivision, a subdivision to the City of Gering, Scotts Bluff County, Nebraska - generally located at the northeast intersection of 10th Street and Lockwood Road. Second by Councilmember O'Neal. There was no discussion. Mayor Ewing called for the vote. "AYES": Shields, Gillen, Cecil, Kinsey, Wiedeman, O'Neal, Morrison, Jackson. "NAYS": None. Abstaining: None. Absent: None. Motion carried.

3. Consider approving an Ag Estate Dwelling Site by Wilford Kaufman Farms Inc. on property located on the East Half of the Southeast Quarter of Section 9 Township 21 North, Range 55 West of the 6th P.M., Scotts Bluff County, Nebraska - generally located at the northwest intersection of Robidoux Road and County Road 20

Engineer Folck explained that the City received an application for an Ag Estate Dwelling Site. The owner of the property would like to separate the existing farmstead from the remainder of the property as an Ag Estate Dwelling Site. The farmstead site consists of 4.81 acres, and the remainder of the property consists of 154.36 acres, 80 acres of which will be held in reserve as agricultural land in order to meet the requirements of the City's Zoning Code. This is an existing farmstead and the remainder of the property meets the minimum requirements by code. The Planning Commission recommended approval at their meeting on April 7. Staff also recommends approval.

Motion by Councilmember Gillen to approve an Ag Estate Dwelling Site by Wilford Kaufman Farms Inc. on property located on the East Half of the Southeast Quarter of Section 9 Township 21 North,

Range 55 West of the 6th P.M., Scotts Bluff County, Nebraska - generally located at the northwest intersection of Robidoux Road and County Road 20. Second by Councilmember Cecil. There was no discussion. Mayor Ewing called for the vote. "AYES": Shields, Gillen, Cecil, Kinsey, Wiedeman, O'Neal, Morrison, Jackson. "NAYS": None. Abstaining: None. Absent: None. Motion carried.

4. Consider approving and authorizing the Mayor to sign a Master Short Form Agreement for Professional Services and Task Order 001 by and between the City of Gering and HDR Engineering, Inc.

Engineer Folck stated that the City's landfill is nearing its final capacity and will need to be closed in accordance with all applicable solid waste regulations. The agreement with HDR Engineering, Inc. is to do the closure design and engineering for the landfill, including construction quality assurance. This will include evaluating different options for closure, such as an ET (evapotranspiration) cap, which would provide more options for long-term use of the site for recreation and reestablishment of vegetation. The City has been working with two different landfill engineering consultants over the last few years and both have done excellent work. Proposals were received from both consultants; staff is recommending that the HDR proposal is the best fit for the City's needs.

Motion by Councilmember Morrison to approve and authorize the Mayor to sign a Master Short Form Agreement for Professional Services and Task Order 001 by and between the City of Gering and HDR Engineering, Inc. Second by Councilmember Wiedeman. There was no discussion. Mayor Ewing called for the vote. "AYES": Shields, Gillen, Cecil, Kinsey, Wiedeman, O'Neal, Morrison, Jackson. "NAYS": None. Abstaining: None. Absent: None. Motion carried.

5. Consider approving and authorizing the Mayor to sign a Memorial Donation and Placement Agreement by and between the City of Gering and Reunited in Heaven (Angel of Hope Memorial Committee)

Director of Parks and Recreation, Amy Seiler, explained the Reunited in Heaven organization has been planning and fund raising since roughly 2017-2018 to build a memorial for parents who have lost children. It will be located in Gentry Park (and was previously approved by Council). This agreement lays out what the City's relationship will be with this organization. It outlines maintenance, costs of repairs, insurance, and those types of things. It can be reviewed periodically to make sure everyone is in line with what each group's expectations are. If someday that organization ceases to exist, there would be another conversation on what it would look going forward.

Councilmember Wiedeman asked if they've started work in that park. Ms. Seiler replied that yes, they have started Phase I which is the ADA walkway that leads to the Angel of Hope Memorial. She further explained the plaza area that would house the Angel of Hope; the statue is actually sitting in the park building shop for the time being.

Motion by Councilmember Wiedeman to approve and authorize the Mayor to sign a Memorial Donation and Placement Agreement by and between the City of Gering and Reunited in Heaven (Angel of Hope Memorial Committee). Second by Councilmember Morrison. There was no discussion. Mayor Ewing called for the vote. "AYES": Shields, Gillen, Cecil, Kinsey, Wiedeman, O'Neal, Morrison, Jackson. "NAYS": None. Abstaining: None. Absent: None. Motion carried.

6. Consider approving and authorizing the Mayor to sign an Oregon Trail Creative District MOU between the City of Gering (Tourism Office), TCD (Trusted Community Development), and the Gering Merchants Association

Director of Tourism, Tina Worthman, explained that the proposed Memorandum of Understanding (MOU) establishes a collaborative partnership between the City of Gering, the Gering Merchants Association, and Trusted Community Development in support of the Gering Oregon Trail Creative District application process through the Nebraska Arts Council Creative Districts Program. The MOU outlines the roles and responsibilities of each partner organization in supporting the planning, promotion, and long-term sustainability of the Creative District. The City of Gering would serve as the lead administrative entity for the district, coordinating project oversight, communication, and implementation efforts in partnership with community stakeholders.

Approval of this item would formalize the partnership structure required for the Creative District application through the Nebraska Arts Council and supports ongoing collaboration focused on arts, culture, placemaking, downtown vitality, and community engagement. The MOU does not create new financial obligations beyond existing or future

approved budget allocations. She stated that their group, comprised of Rita Stinner, Jay Sturdevant, Gretchen Peters, her, and people who are invested in the arts in the community have worked together to make this creative district possible. The proposed district is centered around the downtown corridor – The Civic Plaza, the Civic Center, along M Street and up through Legacy of the Plains to the Scotts Bluff National Monument.

Through community engagement, they asked residents what they wanted to see in the creative district. There is strong interest in murals, sculptures (already in place), programming in the plaza (already happening), and future planning.

Councilmember Gillen asked if there will be a governing board. Ms. Worthman replied that it's a community group; they don't really have a "governing body" at this point. It's more of a collaborative group, similar to Scottsbluff's Creative District; the City of Scottsbluff oversees that part but it's just a group that has a common goal. He asked how expenditures would be handled. Ms. Worthman replied that they would go through the budget process. Once it's designated with the Nebraska Arts Council, there's a \$10,000 grant to start working on a strategic plan. There's also a possibility of up to \$100,000 in continuing grants.

Motion by Councilmember Gillen to approve and authorize the Mayor to sign an Oregon Trail Creative District MOU between the City of Gering (Tourism Office), TCD (Trusted Community Development), and the Gering Merchants Association. Second by Councilmember O'Neal. There was no discussion. Mayor Ewing called for the vote. "AYES": Shields, Gillen, Cecil, Kinsey, Wiedeman, O'Neal, Morrison, Jackson. "NAYS": None. Abstaining: None. Absent: None. Motion carried.

7. Consider approving and authorizing the Mayor to sign an Agreement for Mosquito Control between the City of Gering and the City of Terrytown

Motion by Councilmember Gillen to approve and authorize the Mayor to sign an Agreement for Mosquito Control between the City of Gering and the City of Terrytown. Second by Councilmember Morrison. There was no discussion. Mayor Ewing called for the vote. "AYES": Shields, Gillen, Cecil, Kinsey, Wiedeman, O'Neal, Morrison, Jackson. "NAYS": None. Abstaining: None. Absent: None. Motion carried.

8. Consider Approving Occupation Tax Grant Fund Request for Oregon Trail Days

Tourism Director Worthman stated that the Occupation Tax Advisory Committee reviewed a funding request from the Oregon Trail Days Committee for the 2026 Interactive Experience & Photography Project. The project is designed to enhance visitor engagement through branded photo installations, themed props, and professional photography at multiple Oregon Trail Days locations, including downtown Gering and Five Rocks Amphitheater. These enhancements are intended to encourage multi-day attendance, increase overnight stays, and generate tourism-related promotion through shared imagery and social media content. The Occupation Tax Grant Fund Advisory Committee recommended approval of the full \$4,000 request.

Motion by Councilmember Wiedeman to approve an Occupation Tax Grant Fund Request for Oregon Trail Days in the amount of \$4,000. Second by Councilmember Gillen. There was no discussion. Mayor Ewing called for the vote. "AYES": Shields, Gillen, Cecil, Kinsey, Wiedeman, O'Neal, Morrison, Jackson. "NAYS": None. Abstaining: None. Absent: None. Motion carried.

9. Consider Approving Occupation Tax Grant Fund Request for 308 Truck Show

Ms. Worthman explained that the Drive 308 Truck Show will be held in conjunction with the July 3rd fireworks celebration at/near the amphitheater. The event is intended to attract automotive enthusiasts and visitors to Gering while supporting local businesses and community activity. The Occ Tax Committee recommended partial funding in the amount of \$2,000 to support eligible tourism-related expenses, including City fees, advertising, and lodging expenses associated with the event.

Motion by Councilmember Morrison to approve an Occupation Tax Grant Fund Request for the 308 Truck Show in the amount of \$2,000. Second by Councilmember Gillen. There was no discussion. Mayor Ewing called for the vote. “AYES”: Shields, Gillen, Cecil, Kinsey, Wiedeman, O’Neal, Morrison, Jackson. **“NAYS”:** None. **Abstaining:** None. **Absent:** None. **Motion carried.**

10. Consider Approving Occupation Tax Grant Fund Request for PVC Monument Marathon

Ms. Worthman stated that the advisory committee reviewed a funding request from the WNCC Foundation for the 2026 PVC Monument Marathon. The event attracts runners and visitors from across the region and nation, generating overnight stays, local spending, and tourism exposure for Gering and Scotts Bluff County. Grant funds will support targeted tourism advertising, participant shirts, and professional photography used to promote the event and the community. The committee recommended approval of the full \$10,000 request.

Motion by Councilmember O’Neal to approve an Occupation Tax Grant Fund Request for the Platte Valley Companies Monument Marathon in the amount of \$10,000. Second by Councilmember Weideman. There was no discussion. Mayor Ewing called for the vote. “AYES”: Shields, Gillen, Cecil, Kinsey, Wiedeman, O’Neal, Morrison, Jackson. **“NAYS”:** None. **Abstaining:** None. **Absent:** None. **Motion carried.**

11. Consider Approving Occupation Tax Grant Fund Request for Class B State Golf

Ms. Worthman stated that the Class B State Golf Host Committee applied for support of the 2026 NSAA Class B Boys and Girls State Golf Championships to be held in Gering/Scottsbluff. The event brings high school athletes, coaches, and families from across Nebraska to the area, generating overnight stays, dining, retail activity, and tourism-related spending. The committee recommended approval of the full \$4,000 request to assist with hosting expenses associated with the championships.

Motion by Councilmember Gillen to approve an Occupation Tax Grant Fund Request for Class B State Golf in the amount of \$4,000. Second by Councilmember O’Neal. There was no discussion. Mayor Ewing called for the vote. “AYES”: Shields, Gillen, Cecil, Kinsey, Wiedeman, O’Neal, Morrison, Jackson. **“NAYS”:** None. **Abstaining:** None. **Absent:** None. **Motion carried.**

BIDS/PROPOSALS:

1. Consider approving Parks Department Storage Building Bid – Parks and Recreation Department

Engineer Folck explained that the Parks Department budgeted for a new storage building to replace the one that was taken down when the Ballpark Substation was built. The Electric Department is contributing \$40,000 to the project to reimburse the Parks Department for the building that they had to tear down. The project was publicly bid and one bid was received from Mark Chrisman Trucking for \$153,720, which was higher than what was budgeted. Staff has been working with the contractor to value engineer the project to reduce costs within budget. After reducing the size of the building from 50’X60’ to 42’X60’, and making a few other minor changes such as scheduling, the contractor provided deductions that brought the total project cost to \$115,816, which is within the budgeted amount and leaves a little to do the electrical once it’s built. Staff is comfortable with the changes and believe it’s big enough to meet the needs of the Parks Department. It will be completed within this fiscal year. Staff recommends going with the proposal from Mark Chrisman Trucking, with the noted changes, in the amount of \$115,816.

Councilmember Shields asked the location of the building. Engineer Folck replied that it will be near the Parks Department maintenance building, roughly located on the other side of the sod house; east of Overland Trails Road. Councilmember Morrison asked if in the long run, staff would regret go for the bigger building; could it be added onto in any way? Ms. Folck replied that staff would really like to go bigger, but there aren’t funds to do the bigger building. There isn’t really a way to add on because of the location. Director of Parks and Recreation, Amy Seiler, replied that staff have discussed it and they will have the ability to add a mezzanine which they believe would be sufficient storage up above. She believes the size will work for the department. Engineer Folck added that the walls will be built high enough to add a mezzanine; essentially a loft. Ms. Seiler noted that additional landscaping

will be added after the building is constructed. The building will be a buff color to match some of the other Park Department structures. It will store baseball equipment (in the loft area) and numerous other items.

Motion by Councilmember Gillen to award the Parks Department Storage Building Bid to Mark Chrisman Trucking in the amount of \$115,816.00. Second by Councilmember Wiedeman. There was no discussion. Mayor Ewing called for the vote. "AYES": Shields, Gillen, Cecil, Kinsey, Wiedeman, O'Neal, Morrison, Jackson. "NAYS": None. Abstaining: None. Absent: None. Motion carried.

2. Consider approving the purchase of a 2026 Chevy Silverado 2500HD 4WD Crew Cab Work Truck and long box – Water Department

Public Works Director, Mike Davies, stated that funds were budgeted in the FY26 Budget to replace one pickup that will replace a 2014 Ford F250 pickup with roughly 91,000 miles. That pickup will go to the Wastewater Department and be converted for a spraying truck. He sought bids from the state bid and two local dealerships:

Husker Auto Group	\$49,707.77 - 2026 Chevy Silverado 2500 4x4 Crew Cab
Transwest Ford	\$49,886.00 - 2026 Ford F250 Super Cab XL 4x4
Anderson Ford	\$50,207.00 - 2026 Ford F250 Super Cab XLT 4x4
Team Chevrolet	\$53,165.00 - 2026 Chevy Silverado 2500 4x4 crew cab

Additional equipment will be a single wheel long box (flatbed) estimated at \$11,000 plus \$800 for installation, bringing the total for the pickup and long box to \$60,507.77. Sales tax for the pickup and long box combined will run approximately \$4553.08 for a total of \$66,060.85. He can make up the overage in the Capital Outlay Equipment line item. This vehicle Delivery to dealership is expected within 60-90 days of approval.

Staff recommend Husker Auto Group for the bid. Councilmember Shields suggested considering Transwest Ford since their bid is only a little higher. Mr. Davies explained that they didn't follow the state bid specs; they bid an XL instead of an XLT. Councilmember Morrison asked why they're going with a flatbed. Mr. Davies explained that they've been installing a utility box, but anymore they are running so small; they can't get as much in them. His crew wanted to try a flatbed like some of the other departments to see if that works better. They'll add a few tool boxes. They want to give it a try to see if City staff like it better.

Motion by Councilmember Cecil to approve the purchase of a 2026 Chevy Silverado 2500HD 4WD Crew Cab Work Truck and long box in the amount of \$66,060.85 From Husker Auto Group for the Water Department. Second by Councilmember Morrison. There was no discussion. Mayor Ewing called for the vote. "AYES": Shields, Gillen, Cecil, Kinsey, Wiedeman, O'Neal, Morrison, Jackson. "NAYS": None. Abstaining: None. Absent: None. Motion carried.

RESOLUTIONS:

1. Consider approving Resolution 4-26-2 to reclassify Deputy Finance Director to Senior Account Clerk and to approve an amended Pay Plan for Officers and Employees of the City of Gering

RESOLUTION NO.

BE IT RESOLVED BY THE CITY COUNCIL OF THE CITY OF GERING, NEBRASKA:

1. That the following Pay Plan for positions of the City of Gering, Nebraska primary, full-time positions be approved and effective May 1, 2026.

PAY SCHEDULE - GENERAL EMPLOYEES ONLY

NON-EXEMPT EMPLOYEES

Grade	A	B	C	D	E	F	G	H	I
9	\$15.31	\$16.08	\$16.88	\$17.72	\$18.61	\$19.54	\$20.52	\$21.54	\$22.62
10	\$16.08	\$16.88	\$17.72	\$18.61	\$19.54	\$20.52	\$21.54	\$22.62	\$23.75
11	\$16.88	\$17.72	\$18.61	\$19.54	\$20.52	\$21.54	\$22.62	\$23.75	\$24.94
12	\$17.72	\$18.61	\$19.54	\$20.52	\$21.54	\$22.62	\$23.75	\$24.94	\$26.19
13	\$18.61	\$19.54	\$20.52	\$21.54	\$22.62	\$23.75	\$24.94	\$26.19	\$27.49
14	\$19.54	\$20.52	\$21.54	\$22.62	\$23.75	\$24.94	\$26.19	\$27.49	\$28.87
15	\$20.52	\$21.54	\$22.62	\$23.75	\$24.94	\$26.19	\$27.49	\$28.87	\$30.31
16	\$21.54	\$22.62	\$23.75	\$24.94	\$26.19	\$27.49	\$28.87	\$30.31	\$31.83
17	\$22.62	\$23.75	\$24.94	\$26.19	\$27.49	\$28.87	\$30.31	\$31.83	\$33.42
18	\$23.75	\$24.94	\$26.19	\$27.49	\$28.87	\$30.31	\$31.83	\$33.42	\$35.09
19	\$24.94	\$26.19	\$27.49	\$28.87	\$30.31	\$31.83	\$33.42	\$35.09	\$36.85
20	\$26.19	\$27.49	\$28.87	\$30.31	\$31.83	\$33.42	\$35.09	\$36.85	\$38.69
21	\$27.49	\$28.87	\$30.31	\$31.83	\$33.42	\$35.09	\$36.85	\$38.69	\$40.62

EXEMPT EMPLOYEES ONLY (salaries figured at 80 hours per pay period)

Grade	A	B	C	D	E	F	G	H	I
22	\$28.87	\$30.31	\$31.83	\$33.42	\$35.09	\$36.85	\$38.69	\$40.62	\$42.65
23	\$30.31	\$31.83	\$33.42	\$35.09	\$36.85	\$38.69	\$40.62	\$42.65	\$44.79
24	\$31.83	\$33.42	\$35.09	\$36.85	\$38.69	\$40.62	\$42.65	\$44.79	\$47.03
25	\$33.42	\$35.09	\$36.85	\$38.69	\$40.62	\$42.65	\$44.79	\$47.03	\$49.38
26	\$35.09	\$36.85	\$38.69	\$40.62	\$42.65	\$44.79	\$47.03	\$49.38	\$51.85
27	\$36.85	\$38.69	\$40.62	\$42.65	\$44.79	\$47.03	\$49.38	\$51.85	\$54.44
28	\$38.69	\$40.62	\$42.65	\$44.79	\$47.03	\$49.38	\$51.85	\$54.44	\$57.16
29	\$40.62	\$42.65	\$44.79	\$47.03	\$49.38	\$51.85	\$54.44	\$57.16	\$60.02
30	\$42.65	\$44.79	\$47.03	\$49.38	\$51.85	\$54.44	\$57.16	\$60.02	\$63.02

2. That the following positions in the Classification Plan are assigned to the following Class Grades:

NON-EXEMPT POSITIONS - General Employees Only

Grade	Class Titles	Grade	Class Titles
10	Library Assistant II	14	Recreation Coordinator
12	Animal Control Officer	16	EMS Coordinator
13	Administrative Secretary	18	Senior Account Clerk
13	Customer Service Clerk	18	Deputy City Clerk
13	Landfill Adm.Clerk	19	Combination Building Inspector
14	Admin Support Specialist	19	Engineering Technician
14	Youth Service Librarian	19	Golf Course Superintendent
14	Adult Engagement Librarian	20	City Planner
14	Technical Service Librarian		* denotes positions that are currently unfilled

EXEMPT POSITIONS - General Professional, Administrative, and Executive

Grade	Class Titles	Grade	Class Titles
22	Library Director	25	Director of Parks, Recreation, & Leisure Services
22	Golf Course Professional	27	City Engineer
23	Director of Human Resources	27	Director of Public Works
24	City Clerk/Asst to City Admin	28	Chief of Police
24	Director of Tourism	28	Electric Superintendent
24	Director of Environmental Services	28	Fire Marshal
24	Police Captain	28	Finance Dir/City Treasurer
24	Street Superintendent		

3. That the Pay Schedule for the positions of Patrol Officer, Detective, and Police Sergeant be approved and effective September 29, 2025.

Hourly Pay Schedule

	1	2	3	4	5	6	7	8
Patrol Officer	\$26.91	\$28.26	\$29.67	\$31.15	\$32.71	\$34.34	\$36.06	\$37.86
Police Detective	\$28.30	\$29.72	\$31.20	\$32.76	\$34.40	\$36.12	\$37.92	\$39.82
Police Sergeant	\$30.88	\$32.42	\$34.05	\$35.75	\$37.54	\$39.41	\$41.39	\$43.45

4. That the following Pay Schedule for the below listed IBEW eligible positions of the City of Gering, Nebraska be approved and effective September 29, 2025.

Pay Schedule - IBEW Eligible Employees Only - Hourly Rates

Grade	A	B	C	D	E	F	G	H	I
3	\$ 18.08	\$ 18.98	\$ 19.93	\$ 20.93	\$ 21.98	\$ 23.08	\$ 24.23	\$ 25.44	\$ 26.71
4	\$ 18.98	\$ 19.93	\$ 20.93	\$ 21.98	\$ 23.08	\$ 24.23	\$ 25.44	\$ 26.71	\$ 28.05
5	\$ 19.93	\$ 20.93	\$ 21.98	\$ 23.08	\$ 24.23	\$ 25.44	\$ 26.71	\$ 28.05	\$ 29.45
6	\$ 20.93	\$ 21.98	\$ 23.08	\$ 24.23	\$ 25.44	\$ 26.71	\$ 28.05	\$ 29.45	\$ 30.92
7	\$ 21.98	\$ 23.08	\$ 24.23	\$ 25.44	\$ 26.71	\$ 28.05	\$ 29.45	\$ 30.92	\$ 32.47
8	\$ 23.08	\$ 24.23	\$ 25.44	\$ 26.71	\$ 28.05	\$ 29.45	\$ 30.92	\$ 32.47	\$ 34.09
9	\$ 24.23	\$ 25.44	\$ 26.71	\$ 28.05	\$ 29.45	\$ 30.92	\$ 32.47	\$ 34.09	\$ 35.80
10	\$ 25.44	\$ 26.71	\$ 28.05	\$ 29.45	\$ 30.92	\$ 32.47	\$ 34.09	\$ 35.80	\$ 37.59
11	\$ 26.71	\$ 28.05	\$ 29.45	\$ 30.92	\$ 32.47	\$ 34.09	\$ 35.80	\$ 37.59	\$ 39.47
12	\$ 28.05	\$ 29.45	\$ 30.92	\$ 32.47	\$ 34.09	\$ 35.80	\$ 37.59	\$ 39.47	\$ 41.44
13	\$ 29.45	\$ 30.92	\$ 32.47	\$ 34.09	\$ 35.80	\$ 37.59	\$ 39.47	\$ 41.44	\$ 43.51
14	\$ 30.92	\$ 32.47	\$ 34.09	\$ 35.80	\$ 37.59	\$ 39.47	\$ 41.44	\$ 43.51	\$ 45.69
15	\$ 32.47	\$ 34.09	\$ 35.80	\$ 37.59	\$ 39.47	\$ 41.44	\$ 43.51	\$ 45.69	\$ 47.97
16	\$ 34.09	\$ 35.80	\$ 37.59	\$ 39.47	\$ 41.44	\$ 43.51	\$ 45.69	\$ 47.97	\$ 50.37

HOURLY POSITIONS - IBEW Employees Only

Grade	Class Titles	Grade	Class Titles
3	Cemetery Caretaker / Park Maintenance Worker I	9	Sanitation Coordinator
4	Solid Waste Handler	9	Water/Wastewater Operator III
4	Equipment Operator	10	Electric Line Apprentice
4	Water/Wastewater Operator I	10	Wastewater Treatment Plant Operator
5	Heavy Equipment Operator	10	Electric Meter/Service Man
6	Water/Wastewater Operator II	10	Park Maintenance Supervisor
6	Park Maintenance Worker II	10	Street Supervisor
7	Cemetery Sexton	12	Water/Wastewater Supervisor
8	Master Mechanic	15	Electric Journeyman/Lineman
8	Maintenance Mechanic	16	Electric Line Crew Supervisor
8	Storekeeper/Purchasing Agent		* denotes positions that are currently unfilled

5. That the following Pay Schedule for positions in seasonal and part-time positions of the City be approved and effective January 1, 2026.

PAY SCHEDULE - GENERAL EMPLOYEES - PART TIME & SEASONAL

Grade	A	B	C	D	E	F
1	\$15.00	\$15.25	\$15.50	\$15.75	\$16.00	\$16.25
2	\$15.50	\$15.75	\$16.00	\$16.25	\$16.50	\$16.75
3	\$16.50	\$16.75	\$17.00	\$17.25	\$17.50	\$17.75
4	\$17.50	\$17.75	\$18.00	\$18.25	\$18.50	\$18.75
5	\$18.50	\$18.75	\$19.00	\$19.25	\$19.50	\$19.75
6	\$19.50	\$19.75	\$20.00	\$20.25	\$20.50	\$20.75
7	\$20.00	\$20.25	\$20.50	\$20.75	\$21.00	\$21.25
8	\$20.50	\$20.75	\$21.00	\$21.25	\$21.50	\$21.75

HOURLY POSITIONS - Seasonal & Part time Positions Only

Grade	Class Titles	Grade	Class Titles
1 / A	School Crossing Guard	2	Lifeguard
1 / A	Library Page	3	Maintenance Support-Part Time
1 / A	Clubhouse Attendant I	3	FD Support Tech
1 / A	Pool Cashier	4	Assistant Pool Manager
1 / A	Laborer I	4	Camp Host
1	Fire Intern	4	Electric Intern
1	Laborer II	4	Golf Pro Assistant
1	Clubhouse Attendant II	5	Assistant Clerk - Part Time
2	Tourism Intern	8	Pool Manager
2	Library Assistant I		

Passed and approved this _____ day of _____, 2026.

ATTEST:

City Clerk

Human Resources Director, Shannon Goss, stated that the Deputy Finance Director has submitted a resignation. This position was originally established during a time when the City did not have a full-time Finance Director. With the current organizational structure in place, staff recommends redefining the position to better align with operational needs. After reviewing this year's pay review, it is recommended that the position be reclassified as Senior Account Clerk and placed at Grade 18 on the General Pay Scale. Councilmember Morrison asked what the pay grade was before. Finance Director, Lyndsey Mathews, replied grade 24.

Motion by Councilmember O'Neal to approve Resolution 4-26-2 to reclassify Deputy Finance Director to Senior Account Clerk and to approve an amended Pay Plan for Officers and Employees of the City of Gering. Second by Councilmember Gillen. There was no discussion. Mayor Ewing called for the vote. "AYES": Shields, Gillen, Cecil, Kinsey, Wiedeman, O'Neal, Morrison, Jackson. "NAYS": None. Abstaining: None. Absent: None. Motion carried.

CLOSED SESSION: (Council reserves the right to enter into closed session if deemed necessary.) None.

OPEN COMMENT: Discussion or action by Council regarding unscheduled business will not take place. This section is for citizen comment only. None

ADJOURN:

Motion by Councilmember Gillen to adjourn. Second by Councilmember O'Neal. There was no discussion. Mayor Ewing called for the vote. AYES": Shields, Gillen, Cecil, Kinsey, Wiedeman, O'Neal, Morrison, Jackson. "NAYS": None. Abstaining: None. Absent: None. Motion carried.

Meeting adjourned at 6:43 p.m.

Kent E. Ewing, Mayor

ATTEST:

Kathleen J. Welfl, City Clerk



City of Gering, NE

CLAIMS REPORT

By Vendor Name

Post Dates 4/28/2026 - 5/11/2026
Payment Dates 4/28/2026 - 5/11/2026

Description (Payable)	Account Name	Amount
Vendor: 10298 - 308 PLUMBING SOLUTIONS		
Fund: 207 - CIVIC CENTER		
Department: 06 - Expense		
TANKLESS WATER HEATER	CAPITAL IMPROVEMENTS	14,650.00
		14,650.00
Department 06 - Expense Total:		14,650.00
Fund 207 - CIVIC CENTER Total:		14,650.00
Vendor 10298 - 308 PLUMBING SOLUTIONS Total:		14,650.00
Vendor: 997992 - 911 CUSTOM		
Fund: 114 - PUBLIC SAFETY		
Department: 32 - Police		
NEW PATROL CAR EQUIPMENT	CAPITAL OUTLAY EQUIPMENT	10,222.90
NEW PATROL CAR EQUIPMENT	CAPITAL OUTLAY EQUIPMENT	3,376.86
NEW PATROL CAR EQUIPMENT	CAPITAL OUTLAY EQUIPMENT	892.08
		14,491.84
Department 32 - Police Total:		14,491.84
Fund 114 - PUBLIC SAFETY Total:		14,491.84
Vendor 997992 - 911 CUSTOM Total:		14,491.84
Vendor: 999442 - ACE HARDWARE		
Fund: 101 - GENERAL		
Department: 42 - Parks		
FIELD PAINT	BUILDING/GROUND MAINT	98.90
SPRINKLER PARTS	BUILDING/GROUND MAINT	22.99
TOOL BOX FOR SPRINKLER PA...	DEPT OPERATING SUPPLIES	189.00
IRRIGATION CAP	BUILDING/GROUND MAINT	21.48
SPRINKLER PARTS REFUND	BUILDING/GROUND MAINT	-22.99
SHOP TOWELS FOR CLEANING	DEPT OPERATING SUPPLIES	39.95
		349.33
Department 42 - Parks Total:		349.33
Fund 101 - GENERAL Total:		349.33
Vendor 999442 - ACE HARDWARE Total:		349.33
Vendor: 998228 - ACUSHNET COMPANY		
Fund: 205 - GOLF		
Department: 06 - Expense		
PRO SHOP MERCHANDISE	PRO SHOP MERCHANDISE	185.89
PRO SHOP MERCHANDISE	PRO SHOP MERCHANDISE	185.89
		371.78
Department 06 - Expense Total:		371.78
Fund 205 - GOLF Total:		371.78
Vendor 998228 - ACUSHNET COMPANY Total:		371.78
Vendor: 102900 - ADVANCED SERVICES, INC.		
Fund: 204 - SANITATION		
Department: 06 - Expense		
LABOR FOR PICKING FENCE IN...	OTHER PROFESSIONAL SERVIC...	577.51
		577.51
Department 06 - Expense Total:		577.51
Fund 204 - SANITATION Total:		577.51
Vendor 102900 - ADVANCED SERVICES, INC. Total:		577.51
Vendor: 111500 - ALLO COMMUNICATIONS		
Fund: 101 - GENERAL		
Department: 10 - Administration		
MONTHLY PHONE AND INTER...	PHONE & INTERNET	275.76
		275.76
Department 10 - Administration Total:		275.76

CLAIMS REPORT

Post Dates: 4/28/2026 - 5/11/2026 Payment Dates: 4/28/2026 - 5/11/2026

Description (Payable)	Account Name	Amount
Department: 22 - Eng/Bldg Inspection		
MONTHLY PHONE AND INTER...	PHONE & INTERNET	136.92
		136.92
Department 22 - Eng/Bldg Inspection Total:		136.92
Department: 31 - Fire		
MONTHLY PHONE AND INTER...	PHONE & INTERNET	155.11
		155.11
Department 31 - Fire Total:		155.11
Department: 32 - Police		
MONTHLY PHONE AND INTER...	PHONE & INTERNET	194.00
		194.00
Department 32 - Police Total:		194.00
Department: 34 - Cemetery		
MONTHLY PHONE AND INTER...	PHONE & INTERNET	122.07
		122.07
Department 34 - Cemetery Total:		122.07
Department: 41 - Pool		
MONTHLY PHONE AND INTER...	PHONE & INTERNET	24.63
		24.63
Department 41 - Pool Total:		24.63
Department: 42 - Parks		
MONTHLY PHONE AND INTER...	PHONE & INTERNET	332.42
		332.42
Department 42 - Parks Total:		332.42
Department: 44 - Library		
MONTHLY PHONE AND INTER...	PHONE & INTERNET	259.44
		259.44
Department 44 - Library Total:		259.44
Fund 101 - GENERAL Total:		1,500.35
Fund: 109 - TOURISM		
Department: 06 - Expense		
MONTHLY PHONE AND INTER...	PHONE & INTERNET	69.28
		69.28
Department 06 - Expense Total:		69.28
Fund 109 - TOURISM Total:		69.28
Fund: 110 - RV PARK		
Department: 06 - Expense		
MONTHLY PHONE AND INTER...	PHONE & INTERNET	250.35
		250.35
Department 06 - Expense Total:		250.35
Fund 110 - RV PARK Total:		250.35
Fund: 130 - STREETS		
Department: 06 - Expense		
MONTHLY PHONE AND INTER...	PHONE & INTERNET	119.44
		119.44
Department 06 - Expense Total:		119.44
Fund 130 - STREETS Total:		119.44
Fund: 201 - ELECTRIC		
Department: 06 - Expense		
MONTHLY PHONE AND INTER...	PHONE & INTERNET	235.67
		235.67
Department 06 - Expense Total:		235.67
Fund 201 - ELECTRIC Total:		235.67
Fund: 202 - WATER		
Department: 06 - Expense		
MONTHLY PHONE AND INTER...	PHONE & INTERNET	139.35
		139.35
Department 06 - Expense Total:		139.35
Fund 202 - WATER Total:		139.35
Fund: 203 - WASTEWATER		
Department: 06 - Expense		
MONTHLY PHONE AND INTER...	PHONE & INTERNET	164.78
		164.78
Department 06 - Expense Total:		164.78
Fund 203 - WASTEWATER Total:		164.78

CLAIMS REPORT

Post Dates: 4/28/2026 - 5/11/2026 Payment Dates: 4/28/2026 - 5/11/2026

Description (Payable)	Account Name	Amount
Fund: 204 - SANITATION		
Department: 06 - Expense		
MONTHLY PHONE AND INTER...	PHONE & INTERNET	57.24
		57.24
		Department 06 - Expense Total:
		57.24
		Fund 204 - SANITATION Total:
		57.24
Fund: 205 - GOLF		
Department: 06 - Expense		
MONTHLY PHONE AND INTER...	PHONE & INTERNET	455.26
		455.26
		Department 06 - Expense Total:
		455.26
		Fund 205 - GOLF Total:
		455.26
Fund: 207 - CIVIC CENTER		
Department: 06 - Expense		
MONTHLY PHONE AND INTER...	PHONE & INTERNET	664.76
		664.76
		Department 06 - Expense Total:
		664.76
		Fund 207 - CIVIC CENTER Total:
		664.76
		Vendor 111500 - ALLO COMMUNICATIONS Total:
		3,656.48
Vendor: 118900 - AMAZON CAPITAL SERVICES		
Fund: 101 - GENERAL		
Department: 42 - Parks		
OFFICE SUPPLIES	OFFICE & BUILDING SUPPLIES	37.38
		37.38
		Department 42 - Parks Total:
		37.38
Department: 44 - Library		
1 book-adult services NF	BOOKS	19.99
National Geographic US wall ...	SUMMER READING PROGRAM	27.80
13 books adult services-3 LP	BOOKS	204.84
2 books-adult services NF	BOOKS	41.87
T-shirts for SRP	DEPT OPERATING SUPPLIES	34.22
10 pack Flash Drives	OFFICE & BUILDING SUPPLIES	28.87
		28.87
		Department 44 - Library Total:
		357.59
		Fund 101 - GENERAL Total:
		394.97
Fund: 201 - ELECTRIC		
Department: 06 - Expense		
ball joint	VEH & EQUIPMENT MAINT	25.25
		25.25
		Department 06 - Expense Total:
		25.25
		Fund 201 - ELECTRIC Total:
		25.25
Fund: 204 - SANITATION		
Department: 06 - Expense		
5 CANS OF FLY BAIT	DEPT OPERATING SUPPLIES	158.95
		158.95
		Department 06 - Expense Total:
		158.95
		Fund 204 - SANITATION Total:
		158.95
		Vendor 118900 - AMAZON CAPITAL SERVICES Total:
		579.17
Vendor: 997877 - AMERITAS LIFE INSURANCE CORP.		
Fund: 997 - PAYROLL FUND		
Department: 02 - Liability		
PAYROLL CLAIMS	VISION INS PAYABLE	618.86
		618.86
		Department 02 - Liability Total:
		618.86
		Fund 997 - PAYROLL FUND Total:
		618.86
		Vendor 997877 - AMERITAS LIFE INSURANCE CORP. Total:
		618.86
Vendor: 999613 - AT&T MOBILITY		
Fund: 130 - STREETS		
Department: 06 - Expense		
ON CALL PHONES/TABLETS-P...	PHONE & INTERNET	46.95
		46.95
		Department 06 - Expense Total:
		46.95
		Fund 130 - STREETS Total:
		46.95

CLAIMS REPORT

Post Dates: 4/28/2026 - 5/11/2026 Payment Dates: 4/28/2026 - 5/11/2026

Description (Payable)	Account Name	Amount
Fund: 201 - ELECTRIC		
Department: 06 - Expense		
ON CALL PHONES/TABLETS-P...	PHONE & INTERNET	168.63
		168.63
Department 06 - Expense Total:		168.63
Fund 201 - ELECTRIC Total:		168.63
Fund: 202 - WATER		
Department: 06 - Expense		
ON CALL PHONES/TABLETS-P...	PHONE & INTERNET	168.63
		168.63
Department 06 - Expense Total:		168.63
Fund 202 - WATER Total:		168.63
Vendor: 998610 - B & S RASK GRILL		
Fund: 205 - GOLF		
Department: 06 - Expense		
TOURNAMENT & LEAGUE ME...	TOURNAMENT & LEAGUE ME...	1,020.00
TOURNAMENT & LEAGUE ME...	TOURNAMENT & LEAGUE ME...	4,772.80
		4,772.80
Department 06 - Expense Total:		5,792.80
Fund 205 - GOLF Total:		5,792.80
Vendor 998610 - AT&T MOBILITY Total:		384.21
Vendor: 10423 - BENCHMARK GOVERNMENT SOLUTIONS, LLC		
Fund: 101 - GENERAL		
Department: 32 - Police		
TRAINING MEALS M.BRIDE	TRAINING & CONFERENCES	78.70
		78.70
Department 32 - Police Total:		78.70
Fund 101 - GENERAL Total:		78.70
Vendor 10423 - BENCHMARK GOVERNMENT SOLUTIONS, LLC Total:		78.70
Vendor: 163150 - BENZEL PEST CONTROL		
Fund: 101 - GENERAL		
Department: 31 - Fire		
pest control fire station	VEH & EQUIPMENT MAINT	76.71
		76.71
Department 31 - Fire Total:		76.71
Fund 101 - GENERAL Total:		76.71
Fund: 204 - SANITATION		
Department: 06 - Expense		
PEST CONTROL FOR ALL BUILD...	BUILDING/GROUND MAINT	181.50
		181.50
Department 06 - Expense Total:		181.50
Fund 204 - SANITATION Total:		181.50
Vendor 163150 - BENZEL PEST CONTROL Total:		258.21
Vendor: 10460 - BERGANKDV		
Fund: 101 - GENERAL		
Department: 10 - Administration		
2025 AUDIT FINAL BILLING	OTHER PROFESSIONAL SERVIC...	5,000.00
		5,000.00
Department 10 - Administration Total:		5,000.00
Fund 101 - GENERAL Total:		5,000.00
Fund: 111 - LB840		
Department: 06 - Expense		
2025 AUDIT FINAL BILLING	OTHER PROFESSIONAL SERVIC...	5,000.00
		5,000.00
Department 06 - Expense Total:		5,000.00
Fund 111 - LB840 Total:		5,000.00

CLAIMS REPORT

Post Dates: 4/28/2026 - 5/11/2026 Payment Dates: 4/28/2026 - 5/11/2026

Description (Payable)	Account Name	Amount
Fund: 201 - ELECTRIC		
Department: 06 - Expense		
2025 AUDIT FINAL BILLING	OTHER PROFESSIONAL SERVIC...	16,781.00
		<u>16,781.00</u>
Department 06 - Expense Total:		16,781.00
Fund 201 - ELECTRIC Total:		16,781.00
Fund: 202 - WATER		
Department: 06 - Expense		
2025 AUDIT FINAL BILLING	OTHER PROFESSIONAL SERVIC...	16,781.00
		<u>16,781.00</u>
Department 06 - Expense Total:		16,781.00
Fund 202 - WATER Total:		16,781.00
Fund: 203 - WASTEWATER		
Department: 06 - Expense		
2025 AUDIT FINAL BILLING	OTHER PROFESSIONAL SERVIC...	16,781.00
		<u>16,781.00</u>
Department 06 - Expense Total:		16,781.00
Fund 203 - WASTEWATER Total:		16,781.00
Fund: 204 - SANITATION		
Department: 06 - Expense		
2025 AUDIT FINAL BILLING	OTHER PROFESSIONAL SERVIC...	16,781.00
		<u>16,781.00</u>
Department 06 - Expense Total:		16,781.00
Fund 204 - SANITATION Total:		16,781.00
Vendor 10460 - BERGANKDV Total:		77,124.00
Vendor: 998680 - BLACK HILLS ENERGY		
Fund: 101 - GENERAL		
Department: 31 - Fire		
FIRE/ CIVIC PLAZA	UTILITIES	127.16
FIRE	UTILITIES	174.48
		<u>301.64</u>
Department 31 - Fire Total:		301.64
Department: 42 - Parks		
900 OVERLAND TRL-PARKS	UTILITIES	371.00
760 13TH-PARKS	UTILITIES	131.29
		<u>502.29</u>
Department 42 - Parks Total:		502.29
Department: 44 - Library		
1055 P STREET-LIBRARY	UTILITIES	81.85
		<u>81.85</u>
Department 44 - Library Total:		81.85
Fund 101 - GENERAL Total:		885.78
Fund: 108 - DOWNTOWN DEVELOPMENT		
Department: 06 - Expense		
FIRE/ CIVIC PLAZA	UTILITIES	49.55
		<u>49.55</u>
Department 06 - Expense Total:		49.55
Fund 108 - DOWNTOWN DEVELOPMENT Total:		49.55
Fund: 130 - STREETS		
Department: 06 - Expense		
STREET	UTILITIES	174.39
		<u>174.39</u>
Department 06 - Expense Total:		174.39
Fund 130 - STREETS Total:		174.39
Fund: 201 - ELECTRIC		
Department: 06 - Expense		
ELECT BUILDING	UTILITIES	439.91
ELECTRICAL	UTILITIES	458.37
		<u>898.28</u>
Department 06 - Expense Total:		898.28
Fund 201 - ELECTRIC Total:		898.28

CLAIMS REPORT

Post Dates: 4/28/2026 - 5/11/2026 Payment Dates: 4/28/2026 - 5/11/2026

Description (Payable)	Account Name	Amount
Fund: 204 - SANITATION		
Department: 06 - Expense		
SANITATION	UTILITIES	448.44
		Department 06 - Expense Total: 448.44
		Fund 204 - SANITATION Total: 448.44
		Vendor 998680 - BLACK HILLS ENERGY Total: 2,456.44
 Vendor: 172150 - BLACKBURN MANUFACTURING CO.		
Fund: 201 - ELECTRIC		
Department: 01 - Asset		
flags	INVENTORY	344.50
		Department 01 - Asset Total: 344.50
		Fund 201 - ELECTRIC Total: 344.50
 Fund: 202 - WATER		
Department: 06 - Expense		
Flags	REPAIRS-WTR MAINS/SERVICE...	282.95
		Department 06 - Expense Total: 282.95
		Fund 202 - WATER Total: 282.95
		Vendor 172150 - BLACKBURN MANUFACTURING CO. Total: 627.45
 Vendor: 999209 - BLUFFS FACILITY SOLUTIONS		
Fund: 110 - RV PARK		
Department: 06 - Expense		
SOAP	DEPT OPERATING SUPPLIES	31.72
		Department 06 - Expense Total: 31.72
		Fund 110 - RV PARK Total: 31.72
 Fund: 205 - GOLF		
Department: 06 - Expense		
RESTROOM SUPPLIES	DEPT OPERATING SUPPLIES	47.50
		Department 06 - Expense Total: 47.50
		Fund 205 - GOLF Total: 47.50
 Fund: 207 - CIVIC CENTER		
Department: 06 - Expense		
TOWELS/CLEANER- CIVIC CEN...	OFFICE & BUILDING SUPPLIES	142.53
		Department 06 - Expense Total: 142.53
		Fund 207 - CIVIC CENTER Total: 142.53
		Vendor 999209 - BLUFFS FACILITY SOLUTIONS Total: 221.75
 Vendor: 998841 - BORDER STATES INDUSTRIES, INC		
Fund: 201 - ELECTRIC		
Department: 01 - Asset		
extension pads	INVENTORY	338.50
connectors	INVENTORY	1,398.04
poles	INVENTORY	24,827.13
		Department 01 - Asset Total: 26,563.67
Department: 06 - Expense		
wrench	DEPT OPERATING SUPPLIES	52.01
street lights	DEPT OPERATING SUPPLIES	1,906.91
light	BUILDING/GROUND MAINT	253.85
truck tools	VEH & EQUIPMENT MAINT	1,430.64
		Department 06 - Expense Total: 3,643.41
		Fund 201 - ELECTRIC Total: 30,207.08
		Vendor 998841 - BORDER STATES INDUSTRIES, INC Total: 30,207.08

CLAIMS REPORT

Post Dates: 4/28/2026 - 5/11/2026 Payment Dates: 4/28/2026 - 5/11/2026

Description (Payable)	Account Name	Amount
Vendor: 10646 - BRANDED BILLS		
Fund: 205 - GOLF		
Department: 06 - Expense		
PRO SHOP MERCHANDISE	PRO SHOP MERCHANDISE	494.04
		Department 06 - Expense Total: 494.04
		Fund 205 - GOLF Total: 494.04
		Vendor 10646 - BRANDED BILLS Total: 494.04
 Vendor: 230150 - CALLAWAY GOLF COMPANY		
Fund: 205 - GOLF		
Department: 06 - Expense		
PRO SHOP MERCHANDISE	PRO SHOP MERCHANDISE	1,582.33
PRO SHOP MERCHANDISE	PRO SHOP MERCHANDISE	1,495.97
PRO SHOP MERCHANDISE	PRO SHOP MERCHANDISE	546.24
PRO SHOP MERCHANDISE	PRO SHOP MERCHANDISE	130.55
		Department 06 - Expense Total: 3,755.09
		Fund 205 - GOLF Total: 3,755.09
		Vendor 230150 - CALLAWAY GOLF COMPANY Total: 3,755.09
 Vendor: 10313 - CAMSPOT		
Fund: 110 - RV PARK		
Department: 06 - Expense		
ONLINE BOOKING FEES	SOFTWARE LICENSING	760.14
		Department 06 - Expense Total: 760.14
		Fund 110 - RV PARK Total: 760.14
		Vendor 10313 - CAMSPOT Total: 760.14
 Vendor: 396325 - CENGAGE LEARNING/GAGE		
Fund: 101 - GENERAL		
Department: 44 - Library		
1 book-adult services LP	BOOKS	18.19
1 book-adult services LP	BOOKS	26.64
Credit for returned book	BOOKS	-26.64
Credit for returned book	BOOKS	-25.34
		Department 44 - Library Total: -7.15
		Fund 101 - GENERAL Total: -7.15
		Vendor 396325 - CENGAGE LEARNING/GAGE Total: -7.15
 Vendor: 999260 - CENTURY BUSINESS PRODUCTS, INC		
Fund: 101 - GENERAL		
Department: 10 - Administration		
LYOCERA/MZ500 CI COPIER C...	OFFICE & BUILDING SUPPLIES	149.08
		Department 10 - Administration Total: 149.08
		Fund 101 - GENERAL Total: 149.08
		Vendor 999260 - CENTURY BUSINESS PRODUCTS, INC Total: 149.08
 Vendor: 999240 - COLLABORATIVE SUMMER LIBRARY P		
Fund: 101 - GENERAL		
Department: 44 - Library		
Items for Summer Reading Pr...	SUMMER READING PROGRAM	417.68
		Department 44 - Library Total: 417.68
		Fund 101 - GENERAL Total: 417.68
		Vendor 999240 - COLLABORATIVE SUMMER LIBRARY P Total: 417.68
 Vendor: 10286 - COLUMN SOFTWARE, PBC		
Fund: 101 - GENERAL		
Department: 10 - Administration		
MAY NOTICE OF MEETINGS	PUBLICATIONS	30.00
		Department 10 - Administration Total: 30.00

CLAIMS REPORT

Post Dates: 4/28/2026 - 5/11/2026 Payment Dates: 4/28/2026 - 5/11/2026

Description (Payable)	Account Name	Amount
Department: 22 - Eng/Bldg Inspection		
PLUMBING BOARD MTG 05.18...	OTHER PROFESSIONAL SERVIC...	12.54
PC MEETING NOTICE 05.19.26	OTHER PROFESSIONAL SERVIC...	26.72
		Department 22 - Eng/Bldg Inspection Total: 39.26
Department: 32 - Police		
CIVIL SERVICE MEETING NOTI...	PUBLICATIONS	16.36
		Department 32 - Police Total: 16.36
		Fund 101 - GENERAL Total: 85.62
Fund: 111 - LB840		
Department: 06 - Expense		
PC PH OIKOS TIF 05.19.26	OTHER PROFESSIONAL SERVIC...	57.02
		Department 06 - Expense Total: 57.02
		Fund 111 - LB840 Total: 57.02
		Vendor 10286 - COLUMN SOFTWARE, PBC Total: 142.64
Vendor: 272450 - CONNECTING POINT		
Fund: 101 - GENERAL		
Department: 31 - Fire		
fd copier contract	DEPT OPERATING SUPPLIES	10.63
		Department 31 - Fire Total: 10.63
		Fund 101 - GENERAL Total: 10.63
		Vendor 272450 - CONNECTING POINT Total: 10.63
Vendor: 272700 - CONTRACTORS MATERIALS, INC.		
Fund: 130 - STREETS		
Department: 06 - Expense		
Expansion Joint	STREET MAINTENANCE & REP...	109.20
Hammer Drill Bits	DEPT OPERATING SUPPLIES	86.00
		Department 06 - Expense Total: 195.20
		Fund 130 - STREETS Total: 195.20
		Vendor 272700 - CONTRACTORS MATERIALS, INC. Total: 195.20
Vendor: 998961 - COZAD SIGNS, LLC		
Fund: 109 - TOURISM		
Department: 06 - Expense		
Add wind slits to banners	GVB ADVERTISING	150.00
		Department 06 - Expense Total: 150.00
		Fund 109 - TOURISM Total: 150.00
		Vendor 998961 - COZAD SIGNS, LLC Total: 150.00
Vendor: 289500 - CRESCENT ELECTRIC SUPPLY CO.		
Fund: 201 - ELECTRIC		
Department: 06 - Expense		
connector	DEPT OPERATING SUPPLIES	18.72
		Department 06 - Expense Total: 18.72
		Fund 201 - ELECTRIC Total: 18.72
		Vendor 289500 - CRESCENT ELECTRIC SUPPLY CO. Total: 18.72
Vendor: 998707 - CROELL, INC		
Fund: 110 - RV PARK		
Department: 06 - Expense		
CONCRETE RV PARK	CAPITAL IMPROVEMENTS	2,185.00
CONCRETE RV	CAPITAL IMPROVEMENTS	9,975.00
CONCRETE RV	CAPITAL IMPROVEMENTS	10,875.00
		Department 06 - Expense Total: 23,035.00
		Fund 110 - RV PARK Total: 23,035.00

CLAIMS REPORT

Post Dates: 4/28/2026 - 5/11/2026 Payment Dates: 4/28/2026 - 5/11/2026

Description (Payable)	Account Name	Amount
Fund: 202 - WATER		
Department: 06 - Expense		
Concrete Lockwood RD	REPAIRS-WTR MAINS/SERVICE...	540.00
		Department 06 - Expense Total: 540.00
		Fund 202 - WATER Total: 540.00
		Vendor 998707 - CROELL, INC Total: 23,575.00
 Vendor: 998976 - CROSSCOUNTRY COURIER INC		
Fund: 201 - ELECTRIC		
Department: 06 - Expense		
freight	DEPT OPERATING SUPPLIES	297.53
		Department 06 - Expense Total: 297.53
		Fund 201 - ELECTRIC Total: 297.53
		Vendor 998976 - CROSSCOUNTRY COURIER INC Total: 297.53
 Vendor: 377800 - DEARBORN LIFE INSURANCE COMPAN		
Fund: 101 - GENERAL		
Department: 31 - Fire		
vol ff life insurance	FF/EMT INCENTIVE	113.52
		Department 31 - Fire Total: 113.52
		Fund 101 - GENERAL Total: 113.52
		Vendor 377800 - DEARBORN LIFE INSURANCE COMPAN Total: 113.52
 Vendor: 319150 - DEMCO, INC		
Fund: 101 - GENERAL		
Department: 44 - Library		
Book covers of various sizes	DEPT OPERATING SUPPLIES	306.28
		Department 44 - Library Total: 306.28
		Fund 101 - GENERAL Total: 306.28
		Vendor 319150 - DEMCO, INC Total: 306.28
 Vendor: 997120 - DOOLEY OIL		
Fund: 205 - GOLF		
Department: 06 - Expense		
DIESEL FUEL	FUEL	1,150.50
		Department 06 - Expense Total: 1,150.50
		Fund 205 - GOLF Total: 1,150.50
		Vendor 997120 - DOOLEY OIL Total: 1,150.50
 Vendor: 337880 - DUTTON-LAINSON COMPANY		
Fund: 202 - WATER		
Department: 06 - Expense		
ERT's	METERS	3,989.57
		Department 06 - Expense Total: 3,989.57
		Fund 202 - WATER Total: 3,989.57
		Vendor 337880 - DUTTON-LAINSON COMPANY Total: 3,989.57
 Vendor: 999002 - EAKES INC		
Fund: 101 - GENERAL		
Department: 32 - Police		
LENS WIPES	OFFICE & BUILDING SUPPLIES	19.97
		Department 32 - Police Total: 19.97
		Fund 101 - GENERAL Total: 19.97
		Vendor 999002 - EAKES INC Total: 19.97
 Vendor: 10309 - EAST PENN MANUFACTURING CO.		
Fund: 205 - GOLF		
Department: 06 - Expense		
BATTERIES FOR KAWASAKIE ...	GOLF EQUIPMENT REPAIR	148.30

CLAIMS REPORT

Post Dates: 4/28/2026 - 5/11/2026 Payment Dates: 4/28/2026 - 5/11/2026

Description (Payable)	Account Name	Amount
CORE DEPOSIT REFUND FOR B...	GOLF EQUIPMENT REPAIR	-27.00
Department 06 - Expense Total:		121.30
Fund 205 - GOLF Total:		121.30
Vendor 10309 - EAST PENN MANUFACTURING CO. Total:		121.30
Vendor: 363755 - FASTENAL COMPANY		
Fund: 201 - ELECTRIC		
Department: 06 - Expense		
eyewear gloves	DEPT OPERATING SUPPLIES	138.89
batteries, eyewear	DEPT OPERATING SUPPLIES	146.72
Department 06 - Expense Total:		285.61
Fund 201 - ELECTRIC Total:		285.61
Vendor 363755 - FASTENAL COMPANY Total:		285.61
Vendor: 363850 - FAT BOYS TIRE & AUTO		
Fund: 130 - STREETS		
Department: 06 - Expense		
Backhoe Tires	VEH & EQUIPMENT MAINT	798.00
Department 06 - Expense Total:		798.00
Fund 130 - STREETS Total:		798.00
Vendor 363850 - FAT BOYS TIRE & AUTO Total:		798.00
Vendor: 364200 - FEDEX		
Fund: 203 - WASTEWATER		
Department: 06 - Expense		
Shipping Lab	LAB SERVICE	169.22
Department 06 - Expense Total:		169.22
Fund 203 - WASTEWATER Total:		169.22
Vendor 364200 - FEDEX Total:		169.22
Vendor: 998632 - FIRST NATIONAL BANK OF OMAHA		
Fund: 997 - PAYROLL FUND		
Department: 02 - Liability		
PAYROLL CLAIMS	HSA PAYABLE	10,671.53
Department 02 - Liability Total:		10,671.53
Fund 997 - PAYROLL FUND Total:		10,671.53
Vendor 998632 - FIRST NATIONAL BANK OF OMAHA Total:		10,671.53
Vendor: 998633 - FIRST NATIONAL BANK OMAHA - POLICE		
Fund: 997 - PAYROLL FUND		
Department: 02 - Liability		
PAYROLL CLAIMS	POLICE UNION DUES PAYABLE	584.00
Department 02 - Liability Total:		584.00
Fund 997 - PAYROLL FUND Total:		584.00
Vendor 998633 - FIRST NATIONAL BANK OMAHA - POLICE Total:		584.00
Vendor: 374900 - FLOYD'S TRUCK CENTER, INC.		
Fund: 203 - WASTEWATER		
Department: 06 - Expense		
Sewer jet	VEH & EQUIPMENT MAINT	6.28
Department 06 - Expense Total:		6.28
Fund 203 - WASTEWATER Total:		6.28
Fund: 204 - SANITATION		
Department: 06 - Expense		
AIR HOSE FOR G9.	COLLECTIONS EQUIP MAINT	102.64
Department 06 - Expense Total:		102.64
Fund 204 - SANITATION Total:		102.64
Vendor 374900 - FLOYD'S TRUCK CENTER, INC. Total:		108.92

CLAIMS REPORT

Post Dates: 4/28/2026 - 5/11/2026 Payment Dates: 4/28/2026 - 5/11/2026

Description (Payable)	Account Name	Amount
Vendor: 216375 - FRANCISCOS BUMPER TO BUMPER IN		
Fund: 101 - GENERAL		
Department: 32 - Police		
PD TOW	TOWING & STORAGE	230.00
		Department 32 - Police Total: 230.00
		Fund 101 - GENERAL Total: 230.00
Vendor 216375 - FRANCISCOS BUMPER TO BUMPER IN Total:		230.00
Vendor: 998694 - FRANK PARTS COMPANY		
Fund: 101 - GENERAL		
Department: 34 - Cemetery		
RTV FILTERS	VEH & EQUIPMENT MAINT	59.40
OIL DRY	DEPT OPERATING SUPPLIES	38.68
		Department 34 - Cemetery Total: 98.08
Department: 42 - Parks		
DRAIN HOSE FOR HONDA SPR...	VEH & EQUIPMENT MAINT	63.58
		Department 42 - Parks Total: 63.58
		Fund 101 - GENERAL Total: 161.66
Fund: 202 - WATER		
Department: 06 - Expense		
leak trailer	DEPT OPERATING SUPPLIES	7.60
Service truck	VEH & EQUIPMENT MAINT	137.95
		Department 06 - Expense Total: 145.55
		Fund 202 - WATER Total: 145.55
Fund: 203 - WASTEWATER		
Department: 06 - Expense		
Sewer jet	VEH & EQUIPMENT MAINT	32.66
		Department 06 - Expense Total: 32.66
		Fund 203 - WASTEWATER Total: 32.66
Fund: 205 - GOLF		
Department: 06 - Expense		
SHOP SUPPLIES	DEPT OPERATING SUPPLIES	134.29
BEARING/AIR BLOW GUN	DEPT OPERATING SUPPLIES	15.25
BEARING/AIR BLOW GUN	GOLF EQUIPMENT REPAIR	7.96
WIRE FOR MOWER LIGHTS	GOLF EQUIPMENT REPAIR	56.75
SWITCH FOR MOWER LIGHTS	GOLF EQUIPMENT REPAIR	60.68
		Department 06 - Expense Total: 274.93
		Fund 205 - GOLF Total: 274.93
Vendor 998694 - FRANK PARTS COMPANY Total:		614.80
Vendor: 391600 - FYR-TEK, INC.		
Fund: 101 - GENERAL		
Department: 31 - Fire		
drain valve on 30	VEH & EQUIPMENT MAINT	80.00
		Department 31 - Fire Total: 80.00
		Fund 101 - GENERAL Total: 80.00
Vendor 391600 - FYR-TEK, INC. Total:		80.00
Vendor: 996715 - GALLS, AN ARAMARK COMPANY		
Fund: 101 - GENERAL		
Department: 32 - Police		
UNIFORM SHIRTS	UNIFORMS/PPE	127.48
		Department 32 - Police Total: 127.48
		Fund 101 - GENERAL Total: 127.48
Vendor 996715 - GALLS, AN ARAMARK COMPANY Total:		127.48

CLAIMS REPORT

Post Dates: 4/28/2026 - 5/11/2026 Payment Dates: 4/28/2026 - 5/11/2026

Description (Payable)	Account Name	Amount
Vendor: 998905 - GARRETT TIRES & TREADS		
Fund: 204 - SANITATION		
Department: 06 - Expense		
10 RECAP TIRES FOR GARBAGE.. FUEL, FILTERS & TIRES		2,347.35
	Department 06 - Expense Total:	2,347.35
	Fund 204 - SANITATION Total:	2,347.35
	Vendor 998905 - GARRETT TIRES & TREADS Total:	2,347.35
 Vendor: 405900 - GERING VOLUNTEER FIRE DEPT.		
Fund: 101 - GENERAL		
Department: 31 - Fire		
trvl expnses reimbursement	TRAINING & CONFERENCES	542.00
trvl expnses FDIC 2 ff's	TRAINING & CONFERENCES	31.72
	Department 31 - Fire Total:	573.72
	Fund 101 - GENERAL Total:	573.72
	Vendor 405900 - GERING VOLUNTEER FIRE DEPT. Total:	573.72
 Vendor: 10481 - GOLF & SPORT SOLUTIONS		
Fund: 101 - GENERAL		
Department: 42 - Parks		
INFIELD MIX FOR DOME ROCK .. BUILDING/GROUND MAINT		1,693.72
	Department 42 - Parks Total:	1,693.72
	Fund 101 - GENERAL Total:	1,693.72
	Vendor 10481 - GOLF & SPORT SOLUTIONS Total:	1,693.72
 Vendor: 998413 - GROUND UP CONSTRUCTION & CLEAN		
Fund: 101 - GENERAL		
Department: 10 - Administration		
CITY OF GERING/CIVIC CENTER BUILDING/GROUND MAINT		678.50
	Department 10 - Administration Total:	678.50
Department: 44 - Library		
Monthly janitorial services for... BUILDING/GROUND MAINT		804.00
	Department 44 - Library Total:	804.00
	Fund 101 - GENERAL Total:	1,482.50
Fund: 207 - CIVIC CENTER		
Department: 06 - Expense		
CITY OF GERING/CIVIC CENTER BUILDING/GROUNDS MAINT		2,700.00
	Department 06 - Expense Total:	2,700.00
	Fund 207 - CIVIC CENTER Total:	2,700.00
	Vendor 998413 - GROUND UP CONSTRUCTION & CLEAN Total:	4,182.50
 Vendor: 450050 - HARBOR FREIGHT TOOLS		
Fund: 101 - GENERAL		
Department: 42 - Parks		
VICE,TOOL GRIP	DEPT OPERATING SUPPLIES	143.90
	Department 42 - Parks Total:	143.90
	Fund 101 - GENERAL Total:	143.90
	Vendor 450050 - HARBOR FREIGHT TOOLS Total:	143.90
 Vendor: 459400 - HAWKINS, INC.		
Fund: 101 - GENERAL		
Department: 41 - Pool		
CHLORINE,PUMP HEAD	DEPT OPERATING SUPPLIES	3,231.84
	Department 41 - Pool Total:	3,231.84
	Fund 101 - GENERAL Total:	3,231.84

CLAIMS REPORT

Post Dates: 4/28/2026 - 5/11/2026 Payment Dates: 4/28/2026 - 5/11/2026

Description (Payable)	Account Name	Amount
Fund: 202 - WATER		
Department: 06 - Expense		
Fluoride	CHEMICALS	8,351.50
		Department 06 - Expense Total: 8,351.50
		Fund 202 - WATER Total: 8,351.50
		Vendor 459400 - HAWKINS, INC. Total: 11,583.34
 Vendor: 10057 - HEALTHBREAK, INC.		
Fund: 800 - HEALTH INSURANCE		
Department: 06 - Expense		
WELLNESS PLAN - ADMINISTR...	WELLNESS	625.00
		Department 06 - Expense Total: 625.00
		Fund 800 - HEALTH INSURANCE Total: 625.00
		Vendor 10057 - HEALTHBREAK, INC. Total: 625.00
 Vendor: 510400 - IDEAL LAUNDRY AND CLEANERS, INC.		
Fund: 101 - GENERAL		
Department: 10 - Administration		
MATS-CITY HALL	BUILDING/GROUND MAINT	75.83
		Department 10 - Administration Total: 75.83
Department: 44 - Library		
Monthly door mats and cleani...	OFFICE & BUILDING SUPPLIES	38.25
		Department 44 - Library Total: 38.25
		Fund 101 - GENERAL Total: 114.08
Fund: 204 - SANITATION		
Department: 06 - Expense		
RUGS FOR OFFICE IN BALER B...	BUILDING/GROUND MAINT	59.02
		Department 06 - Expense Total: 59.02
		Fund 204 - SANITATION Total: 59.02
Fund: 205 - GOLF		
Department: 06 - Expense		
MAT RENTAL	BUILDING/GROUND MAINT	22.47
		Department 06 - Expense Total: 22.47
		Fund 205 - GOLF Total: 22.47
Fund: 207 - CIVIC CENTER		
Department: 06 - Expense		
LINENS-CIVIC CENTER	DEPT OPERATING SUPPLIES	187.04
LINENS-CIVIC CENTER	DEPT OPERATING SUPPLIES	277.16
LINENS-CIVIC CENTER	DEPT OPERATING SUPPLIES	131.79
		Department 06 - Expense Total: 595.99
		Fund 207 - CIVIC CENTER Total: 595.99
		Vendor 510400 - IDEAL LAUNDRY AND CLEANERS, INC. Total: 791.56
 Vendor: 511900 - INDEPENDENT PLUMBING & HEATING		
Fund: 101 - GENERAL		
Department: 42 - Parks		
BACKFLOW REPAIR AT JOHAN...	BUILDING/GROUND MAINT	93.00
		Department 42 - Parks Total: 93.00
		Fund 101 - GENERAL Total: 93.00
		Vendor 511900 - INDEPENDENT PLUMBING & HEATING Total: 93.00

CLAIMS REPORT

Post Dates: 4/28/2026 - 5/11/2026 Payment Dates: 4/28/2026 - 5/11/2026

Description (Payable)	Account Name	Amount
Vendor: 998734 - INDOFF INCORPORATED		
Fund: 205 - GOLF		
Department: 06 - Expense		
PRINTER INK	OFFICE & BUILDING SUPPLIES	163.64
		Department 06 - Expense Total: 163.64
		Fund 205 - GOLF Total: 163.64
Vendor 998734 - INDOFF INCORPORATED Total: 163.64		
Vendor: 512159 - INFINITY CONSTRUCTION INC.		
Fund: 110 - RV PARK		
Department: 06 - Expense		
CONCRETE LABOR RV PARK	CAPITAL IMPROVEMENTS	10,419.20
		Department 06 - Expense Total: 10,419.20
		Fund 110 - RV PARK Total: 10,419.20
Fund: 130 - STREETS		
Department: 06 - Expense		
10th & M Street Southeast Ra...	CAPITAL IMPROVEMENTS	6,840.00
		Department 06 - Expense Total: 6,840.00
		Fund 130 - STREETS Total: 6,840.00
Vendor 512159 - INFINITY CONSTRUCTION INC. Total: 17,259.20		
Vendor: 512270 - INGRAM LIBRARY SERVICES		
Fund: 101 - GENERAL		
Department: 44 - Library		
90 books-youth services	BOOKS	929.55
38 books-adult services	BOOKS	600.46
		Department 44 - Library Total: 1,530.01
		Fund 101 - GENERAL Total: 1,530.01
Vendor 512270 - INGRAM LIBRARY SERVICES Total: 1,530.01		
Vendor: 512618 - INTERNAL REVENUE SERVICE		
Fund: 997 - PAYROLL FUND		
Department: 02 - Liability		
941 Deposit	FICA PAYABLE	29,945.88
941 Deposit	FEDERAL W/H PAYABLE	18,555.49
941 Deposit	FICA PAYABLE	7,122.26
		Department 02 - Liability Total: 55,623.63
		Fund 997 - PAYROLL FUND Total: 55,623.63
Vendor 512618 - INTERNAL REVENUE SERVICE Total: 55,623.63		
Vendor: 996536 - INTRALINKS, INC.		
Fund: 101 - GENERAL		
Department: 10 - Administration		
IT SUPPORT	IT SUPPORT	1,496.63
		Department 10 - Administration Total: 1,496.63
Department: 22 - Eng/Bldg Inspection		
IT SUPPORT	IT SUPPORT	229.96
		Department 22 - Eng/Bldg Inspection Total: 229.96
Department: 31 - Fire		
IT SUPPORT	IT SUPPORT	161.50
		Department 31 - Fire Total: 161.50
Department: 32 - Police		
NEGEAR 5-PORT GIGABIT UN...	IT SUPPORT	55.98
IT SUPPORT	IT SUPPORT	2,187.27
		Department 32 - Police Total: 2,243.25
Department: 34 - Cemetery		
IT SUPPORT	IT SUPPORT	92.28
		Department 34 - Cemetery Total: 92.28

CLAIMS REPORT

Post Dates: 4/28/2026 - 5/11/2026 Payment Dates: 4/28/2026 - 5/11/2026

Description (Payable)	Account Name	Amount
Department: 42 - Parks		
IT SUPPORT	IT SUPPORT	92.28
		Department 42 - Parks Total: 92.28
Department: 44 - Library		
IT SUPPORT	IT SUPPORT	587.19
Datto Alto backup service for...	IT SUPPORT	119.00
		Department 44 - Library Total: 706.19
		Fund 101 - GENERAL Total: 5,022.09
Fund: 110 - RV PARK		
Department: 06 - Expense		
IT SUPPORT	IT SUPPORT	92.28
		Department 06 - Expense Total: 92.28
		Fund 110 - RV PARK Total: 92.28
Fund: 130 - STREETS		
Department: 06 - Expense		
IT SUPPORT	IT SUPPORT	258.99
		Department 06 - Expense Total: 258.99
		Fund 130 - STREETS Total: 258.99
Fund: 201 - ELECTRIC		
Department: 06 - Expense		
IT SUPPORT	IT SUPPORT	863.30
		Department 06 - Expense Total: 863.30
		Fund 201 - ELECTRIC Total: 863.30
Fund: 202 - WATER		
Department: 06 - Expense		
IT SUPPORT	IT SUPPORT	288.01
		Department 06 - Expense Total: 288.01
		Fund 202 - WATER Total: 288.01
Fund: 203 - WASTEWATER		
Department: 06 - Expense		
IT SUPPORT	IT SUPPORT	172.66
		Department 06 - Expense Total: 172.66
		Fund 203 - WASTEWATER Total: 172.66
Fund: 204 - SANITATION		
Department: 06 - Expense		
IT SUPPORT	IT SUPPORT	431.65
		Department 06 - Expense Total: 431.65
		Fund 204 - SANITATION Total: 431.65
Fund: 205 - GOLF		
Department: 06 - Expense		
IT SUPPORT	IT SUPPORT	201.68
		Department 06 - Expense Total: 201.68
		Fund 205 - GOLF Total: 201.68
Fund: 207 - CIVIC CENTER		
Department: 06 - Expense		
IT SUPPORT	IT SUPPORT	286.52
		Department 06 - Expense Total: 286.52
		Fund 207 - CIVIC CENTER Total: 286.52
		Vendor 996536 - INTRALINKS, INC. Total: 7,617.18
Vendor: 996492 - IRBY TOOL & SAFETY		
Fund: 201 - ELECTRIC		
Department: 01 - Asset		
tape	INVENTORY	63.37
pull boxes	INVENTORY	3,308.85

CLAIMS REPORT

Post Dates: 4/28/2026 - 5/11/2026 Payment Dates: 4/28/2026 - 5/11/2026

Description (Payable)	Account Name	Amount
couplers	INVENTORY	51.60
connectors	INVENTORY	274.66
splices	INVENTORY	117.18
Department 01 - Asset Total:		3,815.66
Department: 06 - Expense		
cannister,connector	DEPT OPERATING SUPPLIES	259.08
Department 06 - Expense Total:		259.08
Fund 201 - ELECTRIC Total:		4,074.74
Vendor 996492 - IRBY TOOL & SAFETY Total:		4,074.74
Vendor: 999505 - J & A TRAFFIC PRODUCTS		
Fund: 130 - STREETS		
Department: 06 - Expense		
Stop & No Passing Zone Signs	TRAFFIC CONTROL SUPPLIES	621.80
Department 06 - Expense Total:		621.80
Fund 130 - STREETS Total:		621.80
Vendor 999505 - J & A TRAFFIC PRODUCTS Total:		621.80
Vendor: 10302 - JEO CONSULTING GROUP		
Fund: 203 - WASTEWATER		
Department: 06 - Expense		
Annual report	STORMWATER MS4	400.00
Department 06 - Expense Total:		400.00
Fund 203 - WASTEWATER Total:		400.00
Vendor 10302 - JEO CONSULTING GROUP Total:		400.00
Vendor: 999393 - JOHN HANCOCK USA FIRE		
Fund: 997 - PAYROLL FUND		
Department: 02 - Liability		
PAYROLL CLAIMS	PENSION PAYABLE	1,075.74
Department 02 - Liability Total:		1,075.74
Fund 997 - PAYROLL FUND Total:		1,075.74
Vendor 999393 - JOHN HANCOCK USA FIRE Total:		1,075.74
Vendor: 999136 - JOHN HANCOCK USA POLICE		
Fund: 997 - PAYROLL FUND		
Department: 02 - Liability		
PAYROLL CLAIMS	PENSION PAYABLE	10,973.69
Department 02 - Liability Total:		10,973.69
Fund 997 - PAYROLL FUND Total:		10,973.69
Vendor 999136 - JOHN HANCOCK USA POLICE Total:		10,973.69
Vendor: 996767 - JOHN HANCOCK USA		
Fund: 997 - PAYROLL FUND		
Department: 02 - Liability		
PAYROLL CLAIMS	PENSION PAYABLE	94.06
PAYROLL CLAIMS	PENSION PAYABLE	21,526.28
Department 02 - Liability Total:		21,620.34
Fund 997 - PAYROLL FUND Total:		21,620.34
Vendor 996767 - JOHN HANCOCK USA Total:		21,620.34
Vendor: 527500 - L.L. JOHNSON DISTRIBUTING		
Fund: 205 - GOLF		
Department: 06 - Expense		
GREEN CUPS,GAGE	BUILDING/GROUND MAINT	705.08
Department 06 - Expense Total:		705.08
Fund 205 - GOLF Total:		705.08
Vendor 527500 - L.L. JOHNSON DISTRIBUTING Total:		705.08

CLAIMS REPORT

Post Dates: 4/28/2026 - 5/11/2026 Payment Dates: 4/28/2026 - 5/11/2026

Description (Payable)	Account Name	Amount
Vendor: 996401 - LAWSON PRODUCTS		
Fund: 204 - SANITATION		
Department: 06 - Expense		
SURE LOK PLIERS.	DEPT OPERATING SUPPLIES	118.65
		<u>Department 06 - Expense Total:</u> 118.65
		<u>Fund 204 - SANITATION Total:</u> 118.65
		<u>Vendor 996401 - LAWSON PRODUCTS Total:</u> 118.65
 Vendor: 580310 - LEAGUE ASSOC./RISK MANAGEMENT		
Fund: 205 - GOLF		
Department: 06 - Expense		
ENDORSEMENT #14	PROPERTY INSURANCE	2,162.67
		<u>Department 06 - Expense Total:</u> 2,162.67
		<u>Fund 205 - GOLF Total:</u> 2,162.67
		<u>Vendor 580310 - LEAGUE ASSOC./RISK MANAGEMENT Total:</u> 2,162.67
 Vendor: 703450 - LEGACY COOPERATIVE		
Fund: 101 - GENERAL		
Department: 01 - Asset		
gasoline	INVENTORY - UNLEADED GAS	4,936.26
		<u>Department 01 - Asset Total:</u> 4,936.26
		<u>Fund 101 - GENERAL Total:</u> 4,936.26
 Fund: 204 - SANITATION		
Department: 06 - Expense		
969 GALLONS OF #2 RED DEIS...	FUEL, FILTERS & TIRES	4,350.81
		<u>Department 06 - Expense Total:</u> 4,350.81
		<u>Fund 204 - SANITATION Total:</u> 4,350.81
		<u>Vendor 703450 - LEGACY COOPERATIVE Total:</u> 9,287.07
 Vendor: 10433 - LITTLE IT HOUSE		
Fund: 109 - TOURISM		
Department: 06 - Expense		
Website hosting and mainten...	GVB ADVERTISING	1,069.20
		<u>Department 06 - Expense Total:</u> 1,069.20
		<u>Fund 109 - TOURISM Total:</u> 1,069.20
		<u>Vendor 10433 - LITTLE IT HOUSE Total:</u> 1,069.20
 Vendor: 997302 - LOGOZ LLC		
Fund: 101 - GENERAL		
Department: 34 - Cemetery		
TOM'S 2 SHIRTS HAD CITY OF ...	UNIFORMS & CLOTHING	16.00
		<u>Department 34 - Cemetery Total:</u> 16.00
		<u>Fund 101 - GENERAL Total:</u> 16.00
		<u>Vendor 997302 - LOGOZ LLC Total:</u> 16.00
 Vendor: 999169 - MACQUEEN EQUIPMENT, LLC		
Fund: 101 - GENERAL		
Department: 31 - Fire		
bunker boots	UNIFORMS/PPE	279.68
		<u>Department 31 - Fire Total:</u> 279.68
		<u>Fund 101 - GENERAL Total:</u> 279.68
		<u>Vendor 999169 - MACQUEEN EQUIPMENT, LLC Total:</u> 279.68

CLAIMS REPORT

Post Dates: 4/28/2026 - 5/11/2026 Payment Dates: 4/28/2026 - 5/11/2026

Description (Payable)	Account Name	Amount
Vendor: 10639 - MAGPUL INDUSTRIES CORP		
Fund: 101 - GENERAL		
Department: 32 - Police		
MBUS SIGHTS	FIREARM SUPPLIES	367.10
		<u>Department 32 - Police Total: 367.10</u>
		<u>Fund 101 - GENERAL Total: 367.10</u>
		Vendor 10639 - MAGPUL INDUSTRIES CORP Total: 367.10
Vendor: 10014 - MARK CHRISMAN TRUCKING		
Fund: 201 - ELECTRIC		
Department: 06 - Expense		
OREGON TRAIL PARK STORAG...	CAPITAL IMPROVEMENTS	9,944.10
		<u>Department 06 - Expense Total: 9,944.10</u>
		<u>Fund 201 - ELECTRIC Total: 9,944.10</u>
		Vendor 10014 - MARK CHRISMAN TRUCKING Total: 9,944.10
Vendor: 997040 - MATHESON TRI-GAS INC		
Fund: 202 - WATER		
Department: 06 - Expense		
Shop tools	DEPT OPERATING SUPPLIES	29.84
		<u>Department 06 - Expense Total: 29.84</u>
		<u>Fund 202 - WATER Total: 29.84</u>
Fund: 203 - WASTEWATER		
Department: 06 - Expense		
Service truck tools	DEPT OPERATING SUPPLIES	183.55
		<u>Department 06 - Expense Total: 183.55</u>
		<u>Fund 203 - WASTEWATER Total: 183.55</u>
Fund: 204 - SANITATION		
Department: 06 - Expense		
TANK RENTAL	DEPT OPERATING SUPPLIES	56.50
TANK RENTAL	DEPT OPERATING SUPPLIES	56.50
		<u>Department 06 - Expense Total: 113.00</u>
		<u>Fund 204 - SANITATION Total: 113.00</u>
		Vendor 997040 - MATHESON TRI-GAS INC Total: 326.39
Vendor: 996404 - MENARDS		
Fund: 201 - ELECTRIC		
Department: 06 - Expense		
hooks	VEH & EQUIPMENT MAINT	245.74
		<u>Department 06 - Expense Total: 245.74</u>
		<u>Fund 201 - ELECTRIC Total: 245.74</u>
Fund: 203 - WASTEWATER		
Department: 06 - Expense		
T posts	DEPT OPERATING SUPPLIES	57.96
		<u>Department 06 - Expense Total: 57.96</u>
		<u>Fund 203 - WASTEWATER Total: 57.96</u>
Fund: 204 - SANITATION		
Department: 06 - Expense		
4 WOODEN MOVING DOLLIES.	DEPT OPERATING SUPPLIES	51.96
PAIN SUPPLIES AND VACUU...	DEPT OPERATING SUPPLIES	212.66
20 1"X4"X8' TRIM BOARDS	DEPT OPERATING SUPPLIES	219.80
		<u>Department 06 - Expense Total: 484.42</u>
		<u>Fund 204 - SANITATION Total: 484.42</u>
		Vendor 996404 - MENARDS Total: 788.12

CLAIMS REPORT

Post Dates: 4/28/2026 - 5/11/2026 Payment Dates: 4/28/2026 - 5/11/2026

Description (Payable)	Account Name	Amount
Vendor: 998025 - MIDWEST CONNECT		
Fund: 201 - ELECTRIC		
Department: 06 - Expense		
UTILITY BILL MAILINGS	OTHER PROFESSIONAL SERVIC...	975.59
		<u>Department 06 - Expense Total:</u> 975.59
		Fund 201 - ELECTRIC Total: 975.59
Fund: 202 - WATER		
Department: 06 - Expense		
UTILITY BILL MAILINGS	OTHER PROFESSIONAL SERVIC...	975.58
		<u>Department 06 - Expense Total:</u> 975.58
		Fund 202 - WATER Total: 975.58
Fund: 203 - WASTEWATER		
Department: 06 - Expense		
UTILITY BILL MAILINGS	OTHER PROFESSIONAL SERVIC...	975.58
		<u>Department 06 - Expense Total:</u> 975.58
		Fund 203 - WASTEWATER Total: 975.58
Fund: 204 - SANITATION		
Department: 06 - Expense		
UTILITY BILL MAILINGS	OTHER PROFESSIONAL SERVIC...	975.58
		<u>Department 06 - Expense Total:</u> 975.58
		Fund 204 - SANITATION Total: 975.58
		<u>Vendor 998025 - MIDWEST CONNECT Total:</u> 3,902.33
Vendor: 655200 - MOBIUS COMMUNICATIONS COMPANY		
Fund: 203 - WASTEWATER		
Department: 06 - Expense		
Security	DEPT OPERATING SUPPLIES	30.00
		<u>Department 06 - Expense Total:</u> 30.00
		Fund 203 - WASTEWATER Total: 30.00
		<u>Vendor 655200 - MOBIUS COMMUNICATIONS COMPANY Total:</u> 30.00
Vendor: 997658 - MONUMENT SHADOWS MENS GOLF		
Fund: 205 - GOLF		
Department: 06 - Expense		
MEN'S ASSOCIATION FEES	ASSOCIATION FEES	2,540.00
		<u>Department 06 - Expense Total:</u> 2,540.00
		Fund 205 - GOLF Total: 2,540.00
		<u>Vendor 997658 - MONUMENT SHADOWS MENS GOLF Total:</u> 2,540.00
Vendor: 674400 - MUNICIPAL SUPPLY, INC. OF NE.		
Fund: 202 - WATER		
Department: 06 - Expense		
Brass	REPAIRS-WTR MAINS/SERVICE...	764.01
valve and acc	REPAIRS-WTR MAINS/SERVICE...	1,432.88
Brass	REPAIRS-WTR MAINS/SERVICE...	74.82
		<u>Department 06 - Expense Total:</u> 2,271.71
		Fund 202 - WATER Total: 2,271.71
		<u>Vendor 674400 - MUNICIPAL SUPPLY, INC. OF NE. Total:</u> 2,271.71
Vendor: 675955 - MUTUAL OF OMAHA		
Fund: 800 - HEALTH INSURANCE		
Department: 06 - Expense		
LIFE/DISABILITY INSURANCE P...	PREMIUM EXPENSE	5,924.50
		<u>Department 06 - Expense Total:</u> 5,924.50
		Fund 800 - HEALTH INSURANCE Total: 5,924.50
		<u>Vendor 675955 - MUTUAL OF OMAHA Total:</u> 5,924.50

CLAIMS REPORT

Post Dates: 4/28/2026 - 5/11/2026 Payment Dates: 4/28/2026 - 5/11/2026

Description (Payable)	Account Name	Amount
Vendor: 10526 - NC CHILD SUPPORT CENTRALIZED COLLECTIONS		
Fund: 997 - PAYROLL FUND		
Department: 02 - Liability		
REMITTANCE ID 0006198367	CHILD SUPPORT PAYABLE	53.19
		Department 02 - Liability Total: 53.19
		Fund 997 - PAYROLL FUND Total: 53.19
Vendor 10526 - NC CHILD SUPPORT CENTRALIZED COLLECTIONS Total:		53.19
Vendor: 679255 - NEBRASKA DEPT. ENVIRONMENTAL QUALITY		
Fund: 204 - SANITATION		
Department: 06 - Expense		
TITLE 132 CHPT 9 PERMIT APP...	CAPITAL IMPROVEMENTS	250.00
		Department 06 - Expense Total: 250.00
		Fund 204 - SANITATION Total: 250.00
Vendor 679255 - NEBRASKA DEPT. ENVIRONMENTAL QUALITY Total:		250.00
Vendor: 679090 - NEBRASKA CHILD SUPPORT PAYMENT CENTE		
Fund: 997 - PAYROLL FUND		
Department: 02 - Liability		
CHILD SUPPORT PAYMENT	CHILD SUPPORT PAYABLE	252.00
CHILD SUPPORT PAYMENT	CHILD SUPPORT PAYABLE	462.93
		Department 02 - Liability Total: 714.93
		Fund 997 - PAYROLL FUND Total: 714.93
Vendor 679090 - NEBRASKA CHILD SUPPORT PAYMENT CENTE Total:		714.93
Vendor: 681950 - NKC TIRE		
Fund: 204 - SANITATION		
Department: 06 - Expense		
FLAT REPAIR ON G12.	FUEL, FILTERS & TIRES	128.40
		Department 06 - Expense Total: 128.40
		Fund 204 - SANITATION Total: 128.40
Vendor 681950 - NKC TIRE Total:		128.40
Vendor: 689915 - NORTHWEST PIPE FITTINGS, INC		
Fund: 101 - GENERAL		
Department: 42 - Parks		
IRRIGATION SUPPLIES	BUILDING/GROUND MAINT	259.44
REPLACE BACKFLOW MCELL...	BUILDING/GROUND MAINT	1,073.36
PVC CEMENT	BUILDING/GROUND MAINT	39.28
IRRIGATION SUPPLIES	BUILDING/GROUND MAINT	115.85
		Department 42 - Parks Total: 1,487.93
		Fund 101 - GENERAL Total: 1,487.93
Vendor 689915 - NORTHWEST PIPE FITTINGS, INC Total:		1,487.93
Vendor: 10645 - OAK JAY		
Fund: 204 - SANITATION		
Department: 06 - Expense		
INSTALL LVP FLOORING IN W...	BUILDING/GROUND MAINT	6,965.00
		Department 06 - Expense Total: 6,965.00
		Fund 204 - SANITATION Total: 6,965.00
Vendor 10645 - OAK JAY Total:		6,965.00
Vendor: 997546 - ONE CALL CONCEPTS, INC		
Fund: 130 - STREETS		
Department: 06 - Expense		
LOCATE FEES	OTHER PROFESSIONAL SERVIC...	22.69
		Department 06 - Expense Total: 22.69
		Fund 130 - STREETS Total: 22.69

CLAIMS REPORT

Post Dates: 4/28/2026 - 5/11/2026 Payment Dates: 4/28/2026 - 5/11/2026

Description (Payable)	Account Name	Amount
Fund: 201 - ELECTRIC		
Department: 06 - Expense		
LOCATE FEES	OTHER PROFESSIONAL SERVIC...	22.70
		22.70
		Department 06 - Expense Total:
		22.70
		Fund 201 - ELECTRIC Total:
		22.70
Fund: 202 - WATER		
Department: 06 - Expense		
LOCATE FEES	OTHER PROFESSIONAL SERVIC...	22.69
		22.69
		Department 06 - Expense Total:
		22.69
		Fund 202 - WATER Total:
		22.69
Fund: 203 - WASTEWATER		
Department: 06 - Expense		
LOCATE FEES	OTHER PROFESSIONAL SERVIC...	22.69
		22.69
		Department 06 - Expense Total:
		22.69
		Fund 203 - WASTEWATER Total:
		22.69
		Vendor 997546 - ONE CALL CONCEPTS, INC Total:
		90.77
Vendor: 997798 - O'REILLY AUTOMOTIVE STORE		
Fund: 101 - GENERAL		
Department: 31 - Fire		
screw bit set	DEPT OPERATING SUPPLIES	18.99
		18.99
		Department 31 - Fire Total:
		18.99
		Fund 101 - GENERAL Total:
		18.99
		Vendor 997798 - O'REILLY AUTOMOTIVE STORE Total:
		18.99
Vendor: 352150 - PANHANDLE ENVIRONMENTAL SERVICE, INC.		
Fund: 202 - WATER		
Department: 06 - Expense		
Lab	LAB SERVICE	60.00
Lab	LAB SERVICE	182.00
Lab	LAB SERVICE	120.00
		362.00
		Department 06 - Expense Total:
		362.00
		Fund 202 - WATER Total:
		362.00
Fund: 203 - WASTEWATER		
Department: 06 - Expense		
Lab	LAB SERVICE	953.00
lab	LAB SERVICE	679.00
Lab	LAB SERVICE	953.00
lab	LAB SERVICE	679.00
Lab	LAB SERVICE	679.00
		3,943.00
		Department 06 - Expense Total:
		3,943.00
		Fund 203 - WASTEWATER Total:
		3,943.00
		Vendor 352150 - PANHANDLE ENVIRONMENTAL SERVICE, INC. Total:
		4,305.00
Vendor: 10583 - PANHANDLE POWER SYSTEMS LLC		
Fund: 207 - CIVIC CENTER		
Department: 06 - Expense		
NEW WATER HEATERS AND CI...	CAPITAL IMPROVEMENTS	300.00
		300.00
		Department 06 - Expense Total:
		300.00
		Fund 207 - CIVIC CENTER Total:
		300.00
		Vendor 10583 - PANHANDLE POWER SYSTEMS LLC Total:
		300.00
Vendor: 10453 - PAUL REED		
Fund: 110 - RV PARK		
Department: 06 - Expense		
CRUSHED CONCRETE RV PARK	CAPITAL IMPROVEMENTS	2,690.75
CRUSHED CONCRETE RV PARK	CAPITAL IMPROVEMENTS	1,229.00

CLAIMS REPORT

Post Dates: 4/28/2026 - 5/11/2026 Payment Dates: 4/28/2026 - 5/11/2026

Description (Payable)	Account Name	Amount
CRUSHED CONCRETE RV PARK	CAPITAL IMPROVEMENTS	666.50
		<u>Department 06 - Expense Total: 4,586.25</u>
		<u>Fund 110 - RV PARK Total: 4,586.25</u>
		<u>Vendor 10453 - PAUL REED Total: 4,586.25</u>
 Vendor: 999791 - POMP'S TIRE SERVICE INC		
Fund: 201 - ELECTRIC		
Department: 06 - Expense		
tire repair	VEH & EQUIPMENT MAINT	44.94
		<u>Department 06 - Expense Total: 44.94</u>
		<u>Fund 201 - ELECTRIC Total: 44.94</u>
 Fund: 203 - WASTEWATER		
Department: 06 - Expense		
Backhoe tire	LAB SERVICE	226.80
		<u>Department 06 - Expense Total: 226.80</u>
		<u>Fund 203 - WASTEWATER Total: 226.80</u>
		<u>Vendor 999791 - POMP'S TIRE SERVICE INC Total: 271.74</u>
 Vendor: 738470 - POWERPLAN OIB		
Fund: 204 - SANITATION		
Department: 06 - Expense		
TRACK SENSOR FOR 750L DOZ...	LANDFILL EQUIP MAINT	29.56
FILLER CAP FOR 180G EXCAVA...	LANDFILL EQUIP MAINT	154.26
		<u>Department 06 - Expense Total: 183.82</u>
		<u>Fund 204 - SANITATION Total: 183.82</u>
		<u>Vendor 738470 - POWERPLAN OIB Total: 183.82</u>
 Vendor: 739500 - PRAISE WINDOWS		
Fund: 207 - CIVIC CENTER		
Department: 06 - Expense		
WINDOW CLEANING=CIVIC C...	BUILDING/GROUNDS MAINT	350.00
		<u>Department 06 - Expense Total: 350.00</u>
		<u>Fund 207 - CIVIC CENTER Total: 350.00</u>
		<u>Vendor 739500 - PRAISE WINDOWS Total: 350.00</u>
 Vendor: 742800 - PROTEX CENTRAL, INC.		
Fund: 101 - GENERAL		
Department: 10 - Administration		
MAIN ENTRY DOOR TO CITY ...	BUILDING/GROUND MAINT	1,117.48
		<u>Department 10 - Administration Total: 1,117.48</u>
		<u>Fund 101 - GENERAL Total: 1,117.48</u>
		<u>Vendor 742800 - PROTEX CENTRAL, INC. Total: 1,117.48</u>
 Vendor: 999583 - PSI DIGITAL IMAGING SOLUTIONS		
Fund: 101 - GENERAL		
Department: 22 - Eng/Bldg Inspection		
Plotter ink	DEPT OPERATING SUPPLIES	1,153.05
		<u>Department 22 - Eng/Bldg Inspection Total: 1,153.05</u>
		<u>Fund 101 - GENERAL Total: 1,153.05</u>
		<u>Vendor 999583 - PSI DIGITAL IMAGING SOLUTIONS Total: 1,153.05</u>
 Vendor: 998154 - PT HOSE AND BEARING		
Fund: 201 - ELECTRIC		
Department: 06 - Expense		
hardware	DEPT OPERATING SUPPLIES	496.06
		<u>Department 06 - Expense Total: 496.06</u>
		<u>Fund 201 - ELECTRIC Total: 496.06</u>

CLAIMS REPORT

Post Dates: 4/28/2026 - 5/11/2026 Payment Dates: 4/28/2026 - 5/11/2026

Description (Payable)	Account Name	Amount
Fund: 202 - WATER		
Department: 06 - Expense		
Fire hydrant gauge	DEPT OPERATING SUPPLIES	33.86
Hose fittings	DEPT OPERATING SUPPLIES	127.29
	Department 06 - Expense Total:	<u>161.15</u>
	Fund 202 - WATER Total:	<u>161.15</u>
Fund: 204 - SANITATION		
Department: 06 - Expense		
HOSE FOR HOSPITAL COMPAC...	DEPT OPERATING SUPPLIES	141.73
GREASE LINE FOR G15.	COLLECTIONS EQUIP MAINT	55.24
	Department 06 - Expense Total:	<u>196.97</u>
	Fund 204 - SANITATION Total:	<u>196.97</u>
Fund: 205 - GOLF		
Department: 06 - Expense		
HYDRAULIC HOSE FOR JACKS...	GOLF EQUIPMENT REPAIR	50.58
	Department 06 - Expense Total:	<u>50.58</u>
	Fund 205 - GOLF Total:	<u>50.58</u>
	Vendor 998154 - PT HOSE AND BEARING Total:	<u>904.76</u>
Vendor: 750100 - R & C WELDING & FABRICATION		
Fund: 201 - ELECTRIC		
Department: 06 - Expense		
unload tranformer for CS Prec...	DEPT OPERATING SUPPLIES	545.00
	Department 06 - Expense Total:	<u>545.00</u>
	Fund 201 - ELECTRIC Total:	<u>545.00</u>
	Vendor 750100 - R & C WELDING & FABRICATION Total:	<u>545.00</u>
Vendor: 760389 - REGIONAL CARE INC.		
Fund: 800 - HEALTH INSURANCE		
Department: 06 - Expense		
DENTAL PREMIUM - APRIL 20...	PREMIUM EXPENSE	507.50
	Department 06 - Expense Total:	<u>507.50</u>
	Fund 800 - HEALTH INSURANCE Total:	<u>507.50</u>
	Vendor 760389 - REGIONAL CARE INC. Total:	<u>507.50</u>
Vendor: 369890 - RIVERSTONE BANK		
Fund: 997 - PAYROLL FUND		
Department: 02 - Liability		
PAYROLL CLAIMS	IBEW UNION DUES PAYABLE	647.67
	Department 02 - Liability Total:	<u>647.67</u>
	Fund 997 - PAYROLL FUND Total:	<u>647.67</u>
	Vendor 369890 - RIVERSTONE BANK Total:	<u>647.67</u>
Vendor: 10647 - RMA ARMAMENT INC		
Fund: 101 - GENERAL		
Department: 32 - Police		
ARMOR PLATES - SWAT	SWAT TEAM	1,115.36
	Department 32 - Police Total:	<u>1,115.36</u>
	Fund 101 - GENERAL Total:	<u>1,115.36</u>
	Vendor 10647 - RMA ARMAMENT INC Total:	<u>1,115.36</u>
Vendor: 793200 - SANDBERG IMPLEMENT, INC.		
Fund: 101 - GENERAL		
Department: 34 - Cemetery		
KUBOTA 2690 DECK BELTS	VEH & EQUIPMENT MAINT	273.08
	Department 34 - Cemetery Total:	<u>273.08</u>
	Fund 101 - GENERAL Total:	<u>273.08</u>

CLAIMS REPORT

Post Dates: 4/28/2026 - 5/11/2026 Payment Dates: 4/28/2026 - 5/11/2026

Description (Payable)	Account Name	Amount
Fund: 130 - STREETS		
Department: 06 - Expense		
Sweeper Rental	RENTAL - EQUIPMENT	250.00
Bucket Rental	RENTAL - EQUIPMENT	150.00
Skid Steer Wiring Harness	VEH & EQUIPMENT MAINT	5,625.67
Antifreeze	VEH & EQUIPMENT MAINT	18.00
Department 06 - Expense Total:		6,043.67
Fund 130 - STREETS Total:		6,043.67
Fund: 205 - GOLF		
Department: 06 - Expense		
HEDGE TRIMMER	DEPT OPERATING SUPPLIES	323.99
Department 06 - Expense Total:		323.99
Fund 205 - GOLF Total:		323.99
Vendor 793200 - SANDBERG IMPLEMENT, INC. Total:		6,640.74
Vendor: 803350 - SCOTTS BLUFF COUNTY COURT		
Fund: 997 - PAYROLL FUND		
Department: 02 - Liability		
FANKHAUSER CI25 2084	GARNISHMENTS PAYABLE	331.06
Department 02 - Liability Total:		331.06
Fund 997 - PAYROLL FUND Total:		331.06
Vendor 803350 - SCOTTS BLUFF COUNTY COURT Total:		331.06
Vendor: 804650 - SCOTTSBLUFF POLICE DEPARTMENT		
Fund: 101 - GENERAL		
Department: 32 - Police		
RANGE FEES	DUES & SUBSCRIPTIONS	380.00
Department 32 - Police Total:		380.00
Fund 101 - GENERAL Total:		380.00
Vendor 804650 - SCOTTSBLUFF POLICE DEPARTMENT Total:		380.00
Vendor: 804250 - SCOTTSBLUFF-GERING UNITED WAY		
Fund: 997 - PAYROLL FUND		
Department: 02 - Liability		
PAYROLL CLAIMS	UNITED WAY PAYABLE	226.34
Department 02 - Liability Total:		226.34
Fund 997 - PAYROLL FUND Total:		226.34
Vendor 804250 - SCOTTSBLUFF-GERING UNITED WAY Total:		226.34
Vendor: 10201 - SE MUNICIPAL SOLAR (NE), LLC		
Fund: 201 - ELECTRIC		
Department: 06 - Expense		
solar bill	PURCHASED POWER - SE MUN...	9,497.69
Department 06 - Expense Total:		9,497.69
Fund 201 - ELECTRIC Total:		9,497.69
Vendor 10201 - SE MUNICIPAL SOLAR (NE), LLC Total:		9,497.69
Vendor: 812500 - SHERWIN WILLIAMS		
Fund: 204 - SANITATION		
Department: 06 - Expense		
PAINT FOR BALER BUILDING O...	DEPT OPERATING SUPPLIES	297.46
Department 06 - Expense Total:		297.46
Fund 204 - SANITATION Total:		297.46
Vendor 812500 - SHERWIN WILLIAMS Total:		297.46

CLAIMS REPORT

Post Dates: 4/28/2026 - 5/11/2026 Payment Dates: 4/28/2026 - 5/11/2026

Description (Payable)	Account Name	Amount
Vendor: 820550 - SIMON CONTRACTORS		
Fund: 110 - RV PARK		
Department: 06 - Expense		
CRUSHED CONCRETE RV PARK	CAPITAL IMPROVEMENTS	2,402.65
		Department 06 - Expense Total: 2,402.65
		Fund 110 - RV PARK Total: 2,402.65
		Vendor 820550 - SIMON CONTRACTORS Total: 2,402.65
Vendor: 878145 - TEAM CHEVROLET		
Fund: 101 - GENERAL		
Department: 32 - Police		
WING LEASE MAY 2026	WING VEHICLE LEASE	600.00
		Department 32 - Police Total: 600.00
		Fund 101 - GENERAL Total: 600.00
		Vendor 878145 - TEAM CHEVROLET Total: 600.00
Vendor: 10266 - TERESA TOSH		
Fund: 207 - CIVIC CENTER		
Department: 06 - Expense		
CATERING COSTS THRU 4/30/...	CATERING COSTS	13,663.25
MANAGEMENT CONTRACT	MANAGEMENT CONTRACT	5,625.00
		Department 06 - Expense Total: 19,288.25
		Fund 207 - CIVIC CENTER Total: 19,288.25
		Vendor 10266 - TERESA TOSH Total: 19,288.25
Vendor: 998938 - THE TORO COMPANY		
Fund: 205 - GOLF		
Department: 06 - Expense		
IRRIGATION SOFTWARE	SOFTWARE LICENSING	315.00
		Department 06 - Expense Total: 315.00
		Fund 205 - GOLF Total: 315.00
		Vendor 998938 - THE TORO COMPANY Total: 315.00
Vendor: 999286 - TITAN MACHINERY INC.		
Fund: 101 - GENERAL		
Department: 42 - Parks		
CASE B50 TRACTOR DOOR RE...	VEH & EQUIPMENT MAINT	501.60
		Department 42 - Parks Total: 501.60
		Fund 101 - GENERAL Total: 501.60
		Vendor 999286 - TITAN MACHINERY INC. Total: 501.60
Vendor: 894300 - TNEMEC COMPANY, INC.		
Fund: 207 - CIVIC CENTER		
Department: 06 - Expense		
LIGHTS FOR GRAY/WHITE PO...	BUILDING/GROUNDS MAINT	924.36
		Department 06 - Expense Total: 924.36
		Fund 207 - CIVIC CENTER Total: 924.36
		Vendor 894300 - TNEMEC COMPANY, INC. Total: 924.36
Vendor: 10135 - TRANSWEST		
Fund: 201 - ELECTRIC		
Department: 06 - Expense		
truck service	VEH & EQUIPMENT MAINT	221.39
		Department 06 - Expense Total: 221.39
		Fund 201 - ELECTRIC Total: 221.39
		Vendor 10135 - TRANSWEST Total: 221.39

CLAIMS REPORT

Post Dates: 4/28/2026 - 5/11/2026 Payment Dates: 4/28/2026 - 5/11/2026

Description (Payable)	Account Name	Amount
Vendor: 999600 - TYLER TECHNOLOGIES		
Fund: 101 - GENERAL		
Department: 10 - Administration		
TIME & ATTENDANCE SOFTW...	SOFTWARE LICENSING	14.10
		Department 10 - Administration Total: 14.10
Department: 22 - Eng/Bldg Inspection		
TIME & ATTENDANCE SOFTW...	SOFTWARE LICENSING	10.58
		Department 22 - Eng/Bldg Inspection Total: 10.58
Department: 32 - Police		
TIME & ATTENDANCE SOFTW...	SOFTWARE LICENSING	63.35
		Department 32 - Police Total: 63.35
Department: 34 - Cemetery		
TIME & ATTENDANCE SOFTW...	SOFTWARE LICENSING	7.05
		Department 34 - Cemetery Total: 7.05
Department: 42 - Parks		
TIME & ATTENDANCE SOFTW...	SOFTWARE LICENSING	17.60
		Department 42 - Parks Total: 17.60
Department: 44 - Library		
TIME & ATTENDANCE SOFTW...	SOFTWARE LICENSING	14.10
		Department 44 - Library Total: 14.10
		Fund 101 - GENERAL Total: 126.78
Fund: 130 - STREETS		
Department: 06 - Expense		
TIME & ATTENDANCE SOFTW...	SOFTWARE LICENSING	17.60
		Department 06 - Expense Total: 17.60
		Fund 130 - STREETS Total: 17.60
Fund: 201 - ELECTRIC		
Department: 06 - Expense		
TIME & ATTENDANCE SOFTW...	SOFTWARE LICENSING	28.18
REFINE CONFIGURATION & TE...	SOFTWARE LICENSING	72.50
		Department 06 - Expense Total: 100.68
		Fund 201 - ELECTRIC Total: 100.68
Fund: 202 - WATER		
Department: 06 - Expense		
TIME & ATTENDANCE SOFTW...	SOFTWARE LICENSING	21.12
REFINE CONFIGURATION & TE...	SOFTWARE LICENSING	72.50
		Department 06 - Expense Total: 93.62
		Fund 202 - WATER Total: 93.62
Fund: 203 - WASTEWATER		
Department: 06 - Expense		
TIME & ATTENDANCE SOFTW...	SOFTWARE LICENSING	3.52
		Department 06 - Expense Total: 3.52
		Fund 203 - WASTEWATER Total: 3.52
Fund: 204 - SANITATION		
Department: 06 - Expense		
TIME & ATTENDANCE SOFTW...	SOFTWARE LICENSING	45.78
		Department 06 - Expense Total: 45.78
		Fund 204 - SANITATION Total: 45.78
Fund: 205 - GOLF		
Department: 06 - Expense		
TIME & ATTENDANCE SOFTW...	SOFTWARE LICENSING	7.02
		Department 06 - Expense Total: 7.02
		Fund 205 - GOLF Total: 7.02
		Vendor 999600 - TYLER TECHNOLOGIES Total: 395.00

CLAIMS REPORT

Post Dates: 4/28/2026 - 5/11/2026 Payment Dates: 4/28/2026 - 5/11/2026

Description (Payable)	Account Name	Amount
Vendor: 10567 - UNITED HEALTH CARE		
Fund: 800 - HEALTH INSURANCE		
Department: 06 - Expense		
HEALTH INSURANCE PREMIU...	PREMIUM EXPENSE	139,590.69
		<u>Department 06 - Expense Total: 139,590.69</u>
		<u>Fund 800 - HEALTH INSURANCE Total: 139,590.69</u>
		<u>Vendor 10567 - UNITED HEALTH CARE Total: 139,590.69</u>
 Vendor: 999019 - VALLEY AUTO LOCATORS LLC		
Fund: 101 - GENERAL		
Department: 32 - Police		
REPAIR TO JEEP PATRIOT	VEH & EQUIP MAINTEANCE	1,461.36
OIL CHANGE S.SCHNEIDER	VEH & EQUIP MAINTEANCE	84.75
		<u>Department 32 - Police Total: 1,546.11</u>
		<u>Fund 101 - GENERAL Total: 1,546.11</u>
		<u>Vendor 999019 - VALLEY AUTO LOCATORS LLC Total: 1,546.11</u>
 Vendor: 996698 - VERIZON WIRELESS SERVICES, LLC		
Fund: 101 - GENERAL		
Department: 10 - Administration		
COUNCIL TABLETS/DEPT TABL...	PHONE & INTERNET	191.34
		<u>Department 10 - Administration Total: 191.34</u>
Department: 22 - Eng/Bldg Inspection		
COUNCIL TABLETS/DEPT TABL...	PHONE & INTERNET	41.80
		<u>Department 22 - Eng/Bldg Inspection Total: 41.80</u>
		<u>Fund 101 - GENERAL Total: 233.14</u>
		<u>Vendor 996698 - VERIZON WIRELESS SERVICES, LLC Total: 233.14</u>
 Vendor: 942300 - WESCO RECEIVABLES CORP.		
Fund: 201 - ELECTRIC		
Department: 01 - Asset		
switches,covers	INVENTORY	4,858.46
		<u>Department 01 - Asset Total: 4,858.46</u>
		<u>Fund 201 - ELECTRIC Total: 4,858.46</u>
		<u>Vendor 942300 - WESCO RECEIVABLES CORP. Total: 4,858.46</u>
 Vendor: 942350 - WESTERN COOPERATIVE COMPANY		
Fund: 101 - GENERAL		
Department: 01 - Asset		
diesel	INVENTOY - DIESEL FUEL	3,630.38
diesel	INVENTOY - DIESEL FUEL	3,910.04
		<u>Department 01 - Asset Total: 7,540.42</u>
Department: 42 - Parks		
REPAIR TO KUBOTA SPRAYER	VEH & EQUIPMENT MAINT	36.06
		<u>Department 42 - Parks Total: 36.06</u>
		<u>Fund 101 - GENERAL Total: 7,576.48</u>
Fund: 204 - SANITATION		
Department: 06 - Expense		
PROPANE FOR FORKLIFT.	DEPT OPERATING SUPPLIES	55.13
		<u>Department 06 - Expense Total: 55.13</u>
		<u>Fund 204 - SANITATION Total: 55.13</u>
		<u>Vendor 942350 - WESTERN COOPERATIVE COMPANY Total: 7,631.61</u>
		<u><u>Grand Total: 606,079.96</u></u>

Report Summary

Fund Summary

Fund	Expense Amount	Payment Amount
101 - GENERAL	45,594.51	0.00
108 - DOWNTOWN DEVELOPMENT	49.55	0.00
109 - TOURISM	1,288.48	0.00
110 - RV PARK	41,577.59	0.00
111 - LB840	5,057.02	0.00
114 - PUBLIC SAFETY	14,491.84	0.00
130 - STREETS	15,138.73	0.00
201 - ELECTRIC	81,152.66	0.00
202 - WATER	34,603.15	0.00
203 - WASTEWATER	23,169.70	0.00
204 - SANITATION	35,310.32	0.00
205 - GOLF	18,955.33	0.00
207 - CIVIC CENTER	39,902.41	0.00
800 - HEALTH INSURANCE	146,647.69	0.00
997 - PAYROLL FUND	103,140.98	103,140.98
Grand Total:	606,079.96	103,140.98

Account Summary

Account Number	Account Name	Expense Amount	Payment Amount
101-01-1611	INVENTORY - UNLEADED...	4,936.26	0.00
101-01-1612	INVENTOY - DIESEL FUEL	7,540.42	0.00
101-10-6230	IT SUPPORT	1,496.63	0.00
101-10-6305	OFFICE & BUILDING SUP...	149.08	0.00
101-10-6310	PHONE & INTERNET	467.10	0.00
101-10-6327	SOFTWARE LICENSING	14.10	0.00
101-10-6350	BUILDING/GROUND MA...	1,871.81	0.00
101-10-6640	OTHER PROFESSIONAL S...	5,000.00	0.00
101-10-6645	PUBLICATIONS	30.00	0.00
101-22-6230	IT SUPPORT	229.96	0.00
101-22-6300	DEPT OPERATING SUPPL...	1,153.05	0.00
101-22-6310	PHONE & INTERNET	178.72	0.00
101-22-6327	SOFTWARE LICENSING	10.58	0.00
101-22-6640	OTHER PROFESSIONAL S...	39.26	0.00
101-31-6111	FF/EMT INCENTIVE	113.52	0.00
101-31-6213	TRAINING & CONFEREN...	573.72	0.00
101-31-6230	IT SUPPORT	161.50	0.00
101-31-6300	DEPT OPERATING SUPPL...	29.62	0.00
101-31-6310	PHONE & INTERNET	155.11	0.00
101-31-6330	UTILITIES	301.64	0.00
101-31-6340	VEH & EQUIPMENT MAI...	156.71	0.00
101-31-6410	UNIFORMS/PPE	279.68	0.00
101-32-6213	TRAINING & CONFEREN...	78.70	0.00
101-32-6225	DUES & SUBSCRIPTIONS	380.00	0.00
101-32-6230	IT SUPPORT	2,243.25	0.00
101-32-6305	OFFICE & BUILDING SUP...	19.97	0.00
101-32-6310	PHONE & INTERNET	194.00	0.00
101-32-6327	SOFTWARE LICENSING	63.35	0.00
101-32-6330	WING VEHICLE LEASE	600.00	0.00
101-32-6340	VEH & EQUIP MAINTEA...	1,546.11	0.00
101-32-6410	UNIFORMS/PPE	127.48	0.00
101-32-6415	FIREARM SUPPLIES	367.10	0.00
101-32-6417	SWAT TEAM	1,115.36	0.00
101-32-6545	TOWING & STORAGE	230.00	0.00
101-32-6650	PUBLICATIONS	16.36	0.00
101-34-6230	IT SUPPORT	92.28	0.00
101-34-6300	DEPT OPERATING SUPPL...	38.68	0.00
101-34-6310	PHONE & INTERNET	122.07	0.00

Account Summary

Account Number	Account Name	Expense Amount	Payment Amount
101-34-6327	SOFTWARE LICENSING	7.05	0.00
101-34-6340	VEH & EQUIPMENT MAI...	332.48	0.00
101-34-6410	UNIFORMS & CLOTHING	16.00	0.00
101-41-6300	DEPT OPERATING SUPPL...	3,231.84	0.00
101-41-6310	PHONE & INTERNET	24.63	0.00
101-42-6230	IT SUPPORT	92.28	0.00
101-42-6300	DEPT OPERATING SUPPL...	372.85	0.00
101-42-6305	OFFICE & BUILDING SUP...	37.38	0.00
101-42-6310	PHONE & INTERNET	332.42	0.00
101-42-6327	SOFTWARE LICENSING	17.60	0.00
101-42-6330	UTILITIES	502.29	0.00
101-42-6340	VEH & EQUIPMENT MAI...	601.24	0.00
101-42-6350	BUILDING/GROUND MA...	3,395.03	0.00
101-44-6230	IT SUPPORT	706.19	0.00
101-44-6300	DEPT OPERATING SUPPL...	340.50	0.00
101-44-6305	OFFICE & BUILDING SUP...	67.12	0.00
101-44-6310	PHONE & INTERNET	259.44	0.00
101-44-6327	SOFTWARE LICENSING	14.10	0.00
101-44-6330	UTILITIES	81.85	0.00
101-44-6350	BUILDING/GROUND MA...	804.00	0.00
101-44-6543	SUMMER READING PRO...	445.48	0.00
101-44-6651	BOOKS	1,789.56	0.00
108-06-6330	UTILITIES	49.55	0.00
109-06-6310	PHONE & INTERNET	69.28	0.00
109-06-6649	GVB ADVERTISING	1,219.20	0.00
110-06-6230	IT SUPPORT	92.28	0.00
110-06-6305	DEPT OPERATING SUPPL...	31.72	0.00
110-06-6310	PHONE & INTERNET	250.35	0.00
110-06-6327	SOFTWARE LICENSING	760.14	0.00
110-06-6344	CAPITAL IMPROVEMENTS	40,443.10	0.00
111-06-6640	OTHER PROFESSIONAL S...	5,057.02	0.00
114-32-6363	CAPITAL OUTLAY EQUIP...	14,491.84	0.00
130-06-6230	IT SUPPORT	258.99	0.00
130-06-6300	DEPT OPERATING SUPPL...	86.00	0.00
130-06-6310	PHONE & INTERNET	166.39	0.00
130-06-6327	SOFTWARE LICENSING	17.60	0.00
130-06-6330	UTILITIES	174.39	0.00
130-06-6340	RENTAL - EQUIPMENT	400.00	0.00
130-06-6345	VEH & EQUIPMENT MAI...	6,441.67	0.00
130-06-6351	TRAFFIC CONTROL SUPPL...	621.80	0.00
130-06-6460	CAPITAL IMPROVEMENTS	6,840.00	0.00
130-06-6640	OTHER PROFESSIONAL S...	22.69	0.00
130-06-6932	STREET MAINTENANCE &...	109.20	0.00
201-01-1270	INVENTORY	35,582.29	0.00
201-06-6230	IT SUPPORT	863.30	0.00
201-06-6300	DEPT OPERATING SUPPL...	3,860.92	0.00
201-06-6310	PHONE & INTERNET	404.30	0.00
201-06-6327	SOFTWARE LICENSING	100.68	0.00
201-06-6330	UTILITIES	898.28	0.00
201-06-6345	VEH & EQUIPMENT MAI...	1,967.96	0.00
201-06-6350	BUILDING/GROUND MA...	253.85	0.00
201-06-6460	CAPITAL IMPROVEMENTS	9,944.10	0.00
201-06-6640	OTHER PROFESSIONAL S...	17,779.29	0.00
201-06-6730	PURCHASED POWER - SE...	9,497.69	0.00
202-06-6230	IT SUPPORT	288.01	0.00
202-06-6300	DEPT OPERATING SUPPL...	198.59	0.00
202-06-6310	PHONE & INTERNET	307.98	0.00
202-06-6327	SOFTWARE LICENSING	93.62	0.00

Account Summary

Account Number	Account Name	Expense Amount	Payment Amount
202-06-6345	VEH & EQUIPMENT MAI...	137.95	0.00
202-06-6370	REPAIRS-WTR MAINS/SE...	3,094.66	0.00
202-06-6527	CHEMICALS	8,351.50	0.00
202-06-6615	LAB SERVICE	362.00	0.00
202-06-6640	OTHER PROFESSIONAL S...	17,779.27	0.00
202-06-6755	METERS	3,989.57	0.00
203-06-6230	IT SUPPORT	172.66	0.00
203-06-6300	DEPT OPERATING SUPPL...	271.51	0.00
203-06-6310	PHONE & INTERNET	164.78	0.00
203-06-6327	SOFTWARE LICENSING	3.52	0.00
203-06-6345	VEH & EQUIPMENT MAI...	38.94	0.00
203-06-6374	STORMWATER MS4	400.00	0.00
203-06-6615	LAB SERVICE	4,339.02	0.00
203-06-6640	OTHER PROFESSIONAL S...	17,779.27	0.00
204-06-6230	IT SUPPORT	431.65	0.00
204-06-6300	DEPT OPERATING SUPPL...	1,369.34	0.00
204-06-6310	PHONE & INTERNET	57.24	0.00
204-06-6320	FUEL, FILTERS & TIRES	6,826.56	0.00
204-06-6327	SOFTWARE LICENSING	45.78	0.00
204-06-6330	UTILITIES	448.44	0.00
204-06-6350	BUILDING/GROUND MA...	7,205.52	0.00
204-06-6460	CAPITAL IMPROVEMENTS	250.00	0.00
204-06-6541	COLLECTIONS EQUIP MA...	157.88	0.00
204-06-6542	LANDFILL EQUIP MAINT	183.82	0.00
204-06-6640	OTHER PROFESSIONAL S...	18,334.09	0.00
205-06-6230	IT SUPPORT	201.68	0.00
205-06-6300	DEPT OPERATING SUPPL...	521.03	0.00
205-06-6305	OFFICE & BUILDING SUP...	163.64	0.00
205-06-6310	PHONE & INTERNET	455.26	0.00
205-06-6320	FUEL	1,150.50	0.00
205-06-6327	SOFTWARE LICENSING	322.02	0.00
205-06-6345	GOLF EQUIPMENT REPA...	297.27	0.00
205-06-6350	BUILDING/GROUND MA...	727.55	0.00
205-06-6360	PRO SHOP MERCHANDISE	4,620.91	0.00
205-06-6381	TOURNAMENT & LEAGU...	5,792.80	0.00
205-06-6383	ASSOCIATION FEES	2,540.00	0.00
205-06-6450	PROPERTY INSURANCE	2,162.67	0.00
207-06-6106	MANAGEMENT CONTRA...	5,625.00	0.00
207-06-6230	IT SUPPORT	286.52	0.00
207-06-6300	DEPT OPERATING SUPPL...	595.99	0.00
207-06-6305	OFFICE & BUILDING SUP...	142.53	0.00
207-06-6310	PHONE & INTERNET	664.76	0.00
207-06-6350	BUILDING/GROUNDS MA...	3,974.36	0.00
207-06-6460	CAPITAL IMPROVEMENTS	14,950.00	0.00
207-06-6700	CATERING COSTS	13,663.25	0.00
800-06-6131	PREMIUM EXPENSE	146,022.69	0.00
800-06-6318	WELLNESS	625.00	0.00
997-02-2300	FEDERAL W/H PAYABLE	18,555.49	18,555.49
997-02-2301	FICA PAYABLE	37,068.14	37,068.14
997-02-2310	HSA PAYABLE	10,671.53	10,671.53
997-02-2320	UNITED WAY PAYABLE	226.34	226.34
997-02-2330	IBEW UNION DUES PAY...	647.67	647.67
997-02-2346	POLICE UNION DUES PA...	584.00	584.00
997-02-2367	VISION INS PAYABLE	618.86	618.86
997-02-2375	GARNISHMENTS PAYABLE	331.06	331.06
997-02-2376	CHILD SUPPORT PAYABLE	768.12	768.12
997-02-2380	PENSION PAYABLE	33,669.77	33,669.77
	Grand Total:	606,079.96	103,140.98

Project Account Summary

Project Account Key	Expense Amount	Payment Amount
None	605,479.96	103,140.98
301206330	<u>600.00</u>	<u>0.00</u>
Grand Total:	606,079.96	103,140.98

Agenda Item Summary

For the meeting of: May 11, 2026

Agenda item title: Presentation of Law Enforcement Proclamation

Submitted by: George Holthus, Chief of Police and Mayor Ewing

Explanation of the agenda item: In 1962, President John F. Kennedy proclaimed May 15 as National Police Officer's Memorial Day and the calendar week in which May 15th falls as National Police Week. To recognize National Police Week 2026, Police Department personnel have requested that Mayor Ewing publicly read and sign a proclamation at the May 11th regular City Council meeting in observance of National Police Week.

Board/Commission/Staff recommendation: _____

Does this item require the expenditure of funds? Yes X no

Are funds budgeted? Yes no

If no, comments: _____

Estimated Amount _____

Amount Budgeted _____

Department _____

Account _____

Account Description _____

Approval of funds available: _____

City Treasurer/Finance Director

Does this item require a resolution or an ordinance? yes X no

If a resolution or ordinance is required, it must be attached.

Approved for submittal: *George Holthus, Chief of Police*

Mayor, City Administrator or City Department Head

Referred to: _____ **Committee**

All Agenda Item Summaries and the required attachments are due by Noon on the Wednesday prior to the Council meeting. If the Wednesday prior to the City Council is a holiday, the deadline is Tuesday at Noon.

Agenda Item Summary

For the meeting of: May 11, 2026

Agenda item title: Safe Streets for All Grant Application Discussion

Submitted by: **Annie Folck, City Engineer**

Explanation of the agenda item:

The City has spent the past year working on a Safe Streets for All Safety Action Plan. The plan identifies several projects that the City could pursue to help reduce the risk of serious injury and death. The highest priority project in the plan was the 10th Street Corridor.

Staff is now working with the Nebraska Department of Transportation Infrastructure Hub on a Safe Streets for All Implementation Grant. Before submitting the grant, it is important to ensure that Council is aware of the proposed changes to the 10th Street Corridor and if Council would support those changes.

The project identified for the grant would be approximately \$18 million. The City's match would be 20%, and would come out of the half cent sales tax funds for infrastructure that was approved by voters in 2022. This would be a way to help leverage the City's sales tax dollars to accomplish more with the money that has been set aside for this purpose.

In order to qualify for the grant funds, some changes would have to be made to the roadway in order to improve safety. The engineering consultants will join the May 11 meeting virtually and present different options to Council to determine which is the preferred project to pursue for the purposes of the grant application.

Board/Commission/Staff recommendation:

Does this item require the expenditure of funds?	Yes	<input checked="" type="checkbox"/>	no
---	------------	-------------------------------------	-----------

Are funds budgeted?	<input type="checkbox"/>	<input checked="" type="checkbox"/>	no
----------------------------	--------------------------	-------------------------------------	-----------

If no, comments:

Estimated Amount

Amount Budgeted

Department

Account

Account Description

Approval of funds available:

City Treasurer/Finance Director

If a resolution or ordinance is required, it must be attached.

Approved for submittal:

Annie Folck, City Engineer

Mayor, City Administrator or City Department Head

RESOLUTION NO. 5-26-1

**RESOLUTION ADOPTING A TARGET YEAR FOR
ACHIEVING ZERO FATAL AND SERIOUS
INJURY CRASHES
FOR THE CITY OF GERING, NEBRASKA**

WHEREAS, the Safe Streets and Roads for All (SS4A) discretionary grant program was established in the Bipartisan Infrastructure Law (BIL) with the primary purpose of improving roadway safety by significantly reducing or eliminating roadway fatalities and serious injuries through safety action plan development, refinement, and implementation focused on all users; and,

WHEREAS, on December 19, 2024, the City of Gering, Nebraska was awarded SS4A planning & demonstration grant funding by the U.S. Department of Transportation for the creation of a comprehensive safety action plan (CSAP); and,

WHEREAS, on MARCH 23, 2026 the City of Gering, Nebraska adopted by resolution a Comprehensive Safety Action Plan, entitled the City of Gering Safe Passage Initiative Safe Streets and Roads for All Safety Action Plan; and,

WHEREAS, the City of Gering developed this Comprehensive Safety Action Plan with input from regional stakeholders, member agencies, the public, the Nebraska Department of Transportation, and the Federal Highway Administration and in accordance with the requirements of the SS4A discretionary grant program; and,

WHEREAS, the Comprehensive Safety Action Plan will serve as the foundation for future safety investments, guide the prioritization of strategies and projects, position the City to pursue federal SS4A implementation grant funding, and advance the City's commitment to achieving zero fatalities and serious injuries within Gering City limits by the year 2050.

NOW, THEREFORE, BE IT RESOLVED BY THE CITY COUNCIL OF GERING, NEBRASKA:

Section 1. Commitment to Vision Zero. The City of Gering, Nebraska hereby adopts a target year of 2050 for achieving zero fatal and serious injury crashes within Gering city limits.

Section 2. This Resolution shall take effect immediately upon adoption.

PASSED AND APPROVED THIS 11th DAY OF MAY, 2026.

Kent E. Ewing, Mayor

ATTEST:

Kathleen Welfl, City Clerk

CITY OF GERING
APPLICATION FOR KENO FUNDS
(Please type application request)

Name of organization: Stand Up And Play, Gering NE Chapter Date submitted: September 15, 2025
Mailing address: 2585 Country Club Rd., Gering, NE 69341
Phone number: 308.631.4494 Cell Number: _____ Email: cindydickinson@icloud.com

Explain in detail what the Keno Funds will be used for: (purchasing capital, implementing new programs or a special project. Keno Funds may not be used to supplement an operating budget) _____
Grant funds will be used to purchase an adaptive golf cart to be used by all mobility challenged golfers at Monument Shadows Golf Course. The VertaCat cart enables users to navigate the golf course safely and independently. We will also use funds for marketing materials, clinics and promotional events.

SEE ATTACHED

(Please submit a detailed explanation of the program and/or project and how Keno Funds will be used, how it applies to community betterment and who benefits from this on a separate piece of paper and email a Word file document to cmarting@gering.org)

How much money are you requesting? \$20,000

Provide a copy of your annual budget. attached

Do you receive matching funds with the support you receive from the City? yes

If so, who do you receive the funds from? Stand Up and Play Foundation (\$4,000); As of 9/15/25 we have received sponsorships from B&C Steel (\$1,000); Sandberg Imp (\$250); VFW (\$500); DAV (\$500); Scotts Bluff County Tourism grant \$7,000; and \$3375 from individuals.

Have you applied for Keno Funds before? no Have you received Keno Funds before? no

Please provide a date and amount of prior funds received: _____

Describe how your organization impacts the community: The Paramobile/VertaCat will help to establish the designation of Monument Shadows as an ADA compliant golf course, providing accommodations for mobility challenged golfers. This cart is adjustable, fitting the needs of children and adults. It will be available to all individuals requiring the assistance of a mobility cart. This Vertacat will be the first mobility cart in Western Nebraska. Both the DAV and VFW have offered financial assistance as they see a need for the veterans they serve. We have also contacted Camp Scott camp for children as another possible activity for the mobility challenged children they serve.

Stand Up and Play Foundation

Gering NE Chapter

Monument Shadows Golf Course has become one of the most beautiful destination golf courses in Nebraska. With the wonderful exposure of High School State golf tournaments and numerous local events, it is truly a gem in Western Nebraska. We established a local Stand Up and Play Chapter to provide an opportunity to individuals with limited mobility to continue or begin playing golf. The mission of Stand up and Play is to give wheelchair users and those with mobility challenges the chance to stand up again and experience the freedom to play sports. Our goal is to have the first VertaCat Adaptive Mobility cart at Monument Shadows Golf Course for golfers of all ages and abilities by Spring 2026. This cart would be available to all veterans, support organizations, rehab centers, youth and individuals with special needs.

We became interested in this project because Dan, who is a bi-lateral below the knee amputee, has enjoyed the game of golf for many years without assistance. As his neuropathy progresses, his ability to play golf has diminished. We recognize that others experience similar challenges however, they still have the desire to play golf for as long as possible. The physical therapy and positive psychological benefits a disabled person achieves by standing, to actually participate in sports and recreation, has an enormous impact on their lives. It is our desire to provide access for all who want to enjoy our beautiful golf course. Because there are a limited number of golf courses with mobility carts in Nebraska, it will definitely become a destination for travelers seeking adaptive recreation opportunities. It will be the first mobility cart at a Western Nebraska golf course!

This is truly a game changer for individuals who are unable to play golf due to physical limitations. This is an opportunity to resume the social and physical benefits of golfing in beautiful Western Nebraska. We have contacted the Veterans Administration and VFW regarding the use of a mobility cart for the Veterans they serve. In addition, we also contacted Camp Scott Children's camp, as the cart is adaptable for children as well as adults.

The VertaCat mobility cart will be kept at Monument Shadows Golf Course and made available to those needing assistance. A support team from the Stand Up and Play Foundation will deliver the cart to the golf course and conduct extensive training with our local chapter members and golf course staff. This cart is powered by a lithium battery and is targeted to last approximately 10 years with proper maintenance. Since the cart will be kept at the City's golf course, it should be insured by the City of Gering.

We are in the process of soliciting sponsorships and donations to help with the purchase and maintenance of the cart. It is essential that we also receive assistance from the City of Gering. As with all major sponsors, the City's logo to be displayed on the cart and recognition will be in

all literature. To date, we have received \$4,000 from the Stand Up and Play Foundation; \$1,000 from B & C Steel; \$250 from Sandberg Implement; \$500 from the VFW; \$500 from the DAV; \$7,000 grant from Scotts Bluff County Tourism and \$700 from individual donations.

Your support is extremely important to mobility challenged individuals who want the opportunity to enjoy the great game of golf.

Thank you for your consideration.

Dan and Cindy Dickinson

Stand Up and Play, Gering NE

STAND UP AND PLAY ESTIMATED BUDGET

Original purchase (includes delivery cost)	\$30,075
Invoice attached	
Promotional materials	2,000
Special events, clinics	2,000

ANNUAL EXPENSES

Estimated maintenance, cleaning, recharging expenses	
\$50/month	600
	<hr/>
	\$34,675

STAND UP AND PLAY SPONSORS

STAND UP AND PLAY FOUNDATION	\$4,000
B & C STEEL	1,000
SANDBERG IMPLEMENT	250
VFW	500
DAV	500
SCOTTS BLUFF CO TOURISM	7,000
DEB & LEE RUBOTTOM	500
MARV & CATHY HEFTI	1,000
BOB & KAREN HARVEY	25
SHELLEY & DAVE KNUTSON	50
HOWARD & PEGGY OLSEN	500
BRAD & JANA BODE	100
DAN & CINDY DICKINSON	1,000
LNO (Gini Heinz, Shelley Knutson Laurie Morgheim, Darlene Taegler Dawne Wolfe, Cathy Hefti)	200
TOTAL AS OF 1/9/26	\$16,625

Stand Up USA, Inc
 PO Box 371423
 Las Vegas, NV 89137
 standupusa1@gmail.com
 (941) 320-9688

Estimate

Date	Estimate #
6/23/2025	11532

Ship To
Daniel F Dickinson 2585 Country Club Rd. Gering NE 69341

Description	Qty	Rate	Total
*Full adult/child golf package	1	29,300.00	29,300.00
Right/Left handed VertaCat sport golf package			
Shipping		775.00	775.00
Offer includes:			
Offer Includes:			
Adult package			
Golf bag holder			
Easy adjustable stand-up unit adjustable			
Fold-up foot rest			
*Adjustable Foot rest			
Light unit LED front/rear			
Left & Right Storage trunk waterproof			
2 USB ports			
48 Volt Drive wheels all-terrain - (Approved for driving on greens)			
Seat Cushion waterproof			
Cushion Knee belt			
Chest belt			
Waist safety belt			
Cover in standard all white color			
Charger			
Tool set to adjust			
Single rear wheel			
Key ignition (1)			
2 year factory warranty			
*Personal Training and Fitting			
		Total	\$30,075.00

Sample

**RELEASE AND WAIVER OF LIABILITY AGREEMENT
FOR USE OF ADAPTIVE GOLF CARTS**

PLEASE READ CAREFULLY BEFORE SIGNING – IT AFFECTS YOUR LEGAL RIGHTS

BY SIGNING THIS AGREEMENT, YOU ARE AGREEING TO AN ASSUMPTION OF RISK, RELEASE OF LIABILITY & CERTAIN RIGHTS, AND INDEMNITY.

I, _____ (Participant), acknowledge that I have voluntarily agreed to use an adaptive golf cart at a City and County of Denver Golf Course or Denver facility and in consideration of Denver Golf providing adaptive golf carts I agree to the following:

Adaptive carts are specialized mobility devices which enable golfers to participate in customary golf activities on the course and practice areas. I acknowledge that my use of an adaptive golf cart is voluntary. I agree using an adaptive golf cart and playing golf have inherent risks, hazards, and dangers, that may be known or unknown to me.

Failure to properly operate or secure myself in an adaptive cart could result in serious personal injury or death. I agree that I am solely responsible for my own safety, operation of the adaptive cart, and how I am situated in the cart (buckles, cushions, pads, adjustments, additional devices, etc.) I fully understand the controls and the safe operation of the adaptive cart.

Operating an adaptive cart beyond its capabilities or on uneven surfaces or slopes could result in serious personal injury or death. I agree that adaptive golf carts may not provide complete access to every element of the golf course and that I may not always be able to drive the adaptive cart to retrieve or play my ball as it lies. I acknowledge that I am solely responsible for determining the capabilities of the adaptive cart and I will avoid driving into areas where slope, wetness, surface type, topography, curbs, vegetation, or other natural and man-made conditions could allow the cart to slide, tip over, or otherwise harm myself or the cart.

I, on behalf of myself, and my family, agree and promise not to sue and will forever release, waive, and discharge the City and County of Denver and its elected officials, employees, contractors, agents, volunteers, and any sponsoring agencies and entities (collectively, DENVER) from any and all legal liability to me and my personal representatives, executors, heirs, beneficiaries, children, dependents, spouse, relatives, partners, and subrogees, for any and all claims, causes of action, judgements, liens, costs, or expenses of any nature whatsoever (collectively, CLAIMS) that arise from or in any way connected with any injury or illness (including disability or death) or any theft, loss or damage to property, directly or indirectly, related to or associated with my use of an adaptive golf cart **regardless of the cause(s) including condition of the course, condition of the adaptive cart, negligence of DENVER, or others.**

I, on behalf of myself and my family, further agree, jointly and severally, to defend, indemnify, and hold harmless DENVER from and against any and all CLAIMS that arise from or are associated with any injury or illness (including any disability or death) or any theft, loss or damage to property caused by my deliberate acts or by negligence, in whole or part, and resulting from or associated with my use of an adaptive golf cart or my participation in any Denver Golf activity.

I further agree that DENVER is not responsible for any damage to, or loss or theft of my personal property. No bailment or other legal duty exists on DENVER's part with respect to my personal property.

I have carefully read, clearly understand, and voluntarily sign this release and waiver agreement. I acknowledge and affirm that **I am at least 18 years old** and that this release and waiver agreement is legally binding. Failure to complete and properly sign this release and waiver agreement will result in the denial to rent or use a Denver Golf adaptive golf cart.

_____ Signature of Participant	_____ Mailing Address	_____ City	_____ State	_____ Zip
_____ Print Name	_____ Telephone			
_____ Date	_____ email			

If participant is under the age of 18 legal parent or guardian acknowledgement and signature is required here:

I have carefully read, clearly understand, and voluntarily sign this release and waiver agreement. I acknowledge and affirm that I am the legal parent or guardian of _____ (Participant) and that this release and waiver agreement is legally binding on their behalf. Failure to complete and properly sign this release and waiver agreement will result in the denial to rent or use a Denver Golf adaptive golf cart.

_____ Signature of legal parent or guardian	_____ Mailing Address	_____ City	_____ State	_____ Zip
_____ Print Name	_____ Telephone			
_____ Date	_____ email			

VertaCat

For more information contact
760-212-0256 standupusa1@gmail.com

Stand Tall, roam free, and stand and play the Vertacat way



At VertaCat, we envision a world where mobility limitations do not hamper your freedom to engage in your favorite outdoor activities. Our Stand-On-Command All-Terrain Mobility Rider provides a revolutionized approach to personal mobility, allowing you to stand upright and explore off-road terrains with effortless ease.

With VertaCat, you can immerse in the thrill of golf, archery, or simply the joy of nature, without worrying about your mobility needs. Powered by our "Friction-Free" stand-up assist and packed with exclusive "Cat Smart" safety features, VertaCat is your ideal companion for any outdoor adventure.

Stand tall, roam free, and "Stand and play the VertaCat way".

Vertacat / STANDUP FOR A BETTER QUALITY OF LIFE

for more **information** contact 760-212-0256
standupusa1@gmail.com

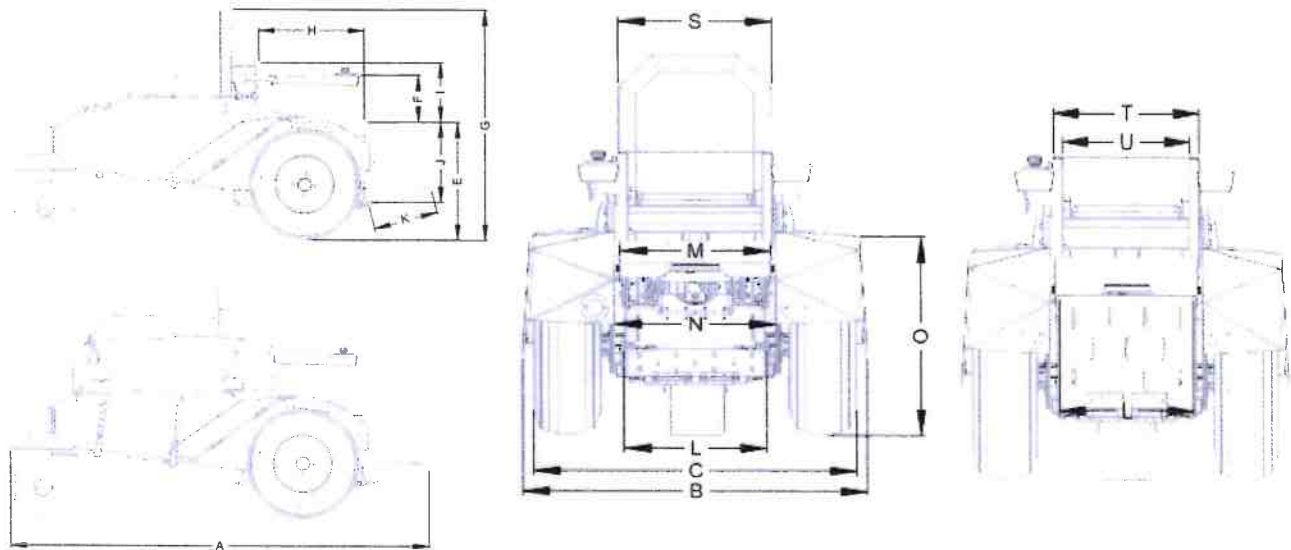

Performance		
Top Speed		8.5 mph
Range		Up to Fifteen miles
Max Safe Slope		30 degrees
Sideway inclination		17 degrees
Turning Radius		106 inches
Battery		
Chemistry		Lithium Iron Phosphate
Max Voltage		58 Volts VDC maximum
Cycle Life		Over 4,000 Cycles
Reference letter	Value (Inch))	Description
A	75.4	Overall length with bumper and footrest
B	36.8	Overall width to widest point of fenders
n/a	680 Lbs.	Total Weight without rider, golf clubs or accessories
C	34.5	Width outside front tires
D	41.6	Overall width with golf bag to widest point of fender
E	21.6 – 28.1	Top of seat to ground (no seat cushion or tire deflection)
F	6.4 – 8.5	Top of armrest metal to top of seat (no seat cushion deflection)
G	42.1	Top of utility bar to ground (no tire deflection)
H	14.1 – 19.1	Front of backrest to front of seat (no backrest deflection)
I	10 – 13.5	Top of backrest to top of seat cushion (no seat cushion deflection)
J	14.7 – 21.2	Top of seat cushion to heel of footrest (no seat cushion deflection)
K	11.6	Footrest length
L	15.2	Footrest inside width
M	16	Seat cushion front width
N	17.2	Seat width inside fenders
O	22.1	Outside edge of fender to ground (no tire deflection)
P	58.5	Overall length without the bumper installed and with the footrest up
Q	27.6	Top of utility bar brackets to ground (no tire deflection)
R	31.6 – 41.6	Top of backrest to ground (no tire deflection)
S	16.4	Utility bar outside width
T	16.3	Backrest outside width
U	14.3	Backrest inside width
V	65.1	Overall length with bumper installed and the footrest up

Vertacat / STANDUP FOR A BETTER QUALITY OF LIFE

for more information contact 760-212-0256
standupusa1@gmail.com



STAND UP AND PLAY

FOUNDATION

2024 ANNUAL REPORT



A MESSAGE FROM OUR FOUNDER

As we reflect on 2024, I am inspired by the incredible momentum we've built together at the Stand Up and Play Foundation. Our mission to enrich communities through adaptive golf has sparked meaningful connections, healing, and transformation - not just for individuals, but for entire communities.

This past year, we've seen the power of adaptive golf bring people together, fostering a sense of belonging and empowerment. Our adaptive golf programs have been a catalyst for change, and I'm grateful to have witnessed the impact firsthand.

Some notable highlights from 2024 include:

- Awarding 20 grants that opened doors for adaptive athletes, adventurers, and first-time golfers.
- Launching our Stand Up and Play Long Beach and San Antonio Chapters, expanding our Veterans program in California and Texas.
- Awarding \$179,757.50 through our grant programs, supporting both individuals and organizations that are driving positive change for those with mobility challenges, paralysis, childhood disabilities, and stroke survivors.

At the heart of our work are the stories of resilience, hope, and transformation. It's the athletes who once thought standing up to play golf was impossible, the mentors who inspired breakthroughs, and the communities who embraced new possibilities.

As we look ahead to 2025, our vision is ambitious: to empower communities and golf courses to spark ripples of transformation that extend far beyond our programs. We're confident that, together, we can build a better world, one stroke at a time.

Thank you for being part of this journey. Your unwavering support and belief in our mission mean the world to us.

With gratitude and appreciation,

Anthony Netto

Founder and President
Stand Up and Play Foundation
941-320-9688



"WE RISE BY LIFTING OTHERS" - ROBERT INGERSOLL

City of Gering Keno Review Committee,

Per your request, we are pleased to supply additional information to you regarding the Stand Up and Play program to provide golfing opportunities for mobility challenged golfers at Monument Shadows Golf Course.

Based on the letter we received February 20, 2026, the following information will address the items listed:

- **Input from City Staff and the Park Department on training, staffing and operation of the VertaCat mobility cart.**
 - The initial VertaCat training will be provided by Stand Up and Play staff at no additional charge. When the VertaCat is delivered, their representative will provide a full day of training to go over maintenance, fitting for different types of disabilities and also hold an Adaptive Golf Clinic. All travel and costs connected to the delivery of the VertaCat are covered by the Stand Up and Play Foundation.
 - Monument Shadows Golf Course Staff has obtained information from the Stand Up and Play staff and City of Denver-Golf who have a VertaCat. It is their suggestion to have at least one to two staff members and/or volunteers trained to assist golfers. The initial training lasts approximately 1 hour. Amy Seiler, Director of Parks, Recreation & Leisure Services and Robert Thomason, PGA Golf Pro, will initially receive the training, and then will train volunteers and specific pro shop staff. No additional staff will need to be hired to assist with the training and use of the mobility cart. The trained employees and volunteers will help fitting participants with equipment set up and safety checks, guiding users on the mobility cart and provide driving instructions for new users.
 - The Golf Pro will create a list of volunteers trained to assist golfers. These volunteers then can be assigned to assist VertaCat golfers as needed.
 - Once volunteers and staff are trained Golf Pro will conduct in-service trainings for staff and volunteers to ensure knowledge of equipment is up to date.
 - A golfer's first training session would last approximately 30 to 45 minutes to get properly fitted and run through the controls. To be certified VertaCat user will be required to demonstrate ability to do various tasks on the course such as navigating hills, around vegetation and avoiding water hazards. Golfers will need to provide their own assistance if they need help transferring to the VertaCat.
 - Every certified adaptive golfer who receives the training will be documented at the course and be issued a certification card they will need to present to utilize the equipment.

- Each user of the VertaCat will sign the Release and Waiver of Liability Agreement. Attached are draft forms of the release and waiver which will be reviewed by the City Attorney if funding is approved.

- **Maintenance Costs, Insurance and Future Use**
 - The VertaCat has a two-year warranty for all moving parts and batteries. The device is targeted to last approximately 8-10 years based on use and continued maintenance, which is similar lifespan for equipment at Monument Shadows. We have estimated the maintenance costs at \$50/month for budget purposes.
 - Insurance costs for VertaCat will be \$537 per year.
 - Future Use will be dependent on promotion and regional awareness. We will be supporting partnerships with our local sponsors, the many organizations that assist people with mobility challenges and our local Veteran organizations. The VertaCat will be listed on the Monument Shadows Golf Course website as mobility equipment available for disabled golfers. DAV and VFW have already pledged their support and will promote to their organizations.
 - There is no way to know how often the VertaCat will be used at the golf course. The question that should be asked is how many people are not playing golf or having the opportunity to learn the game of golf at our public course because they do not have the ability to access the golf course. Giving those with mobility challenges an opportunity to enjoy the great game of golf at our beautiful course shows that our community cares about the quality of life and opportunities for all people. Whether they are beginners, or have played for many years and are unable to continue due to health conditions, the VertaCat will help them stay in the game.

Funding Request

Our original application had a requested amount of \$20,000. We have received additional donations including the recent donation of \$1,000 from the Veterans Service Office, because they are so excited to see this program succeed. This donation increases our total amount of funds raised to \$17,725. The invoice for the VertaCat is \$30,075, changing the difference of our request to **\$12,450**.

We appreciate the opportunity to apply for KENO funds. We look forward to the opportunity to partner with Keno and the City of Gering to provide a VertaCat Mobility Cart for Monument Shadows Golf Course.

Stand Up and Play, Gering NE Chapter

Adaptive Golf Fact Sheet

Congratulations on completing the adaptive cart training session. We look forward to seeing you again soon!

A lot of information was presented during your training so please keep this fact sheet handy for reference as you continue to use adaptive golf carts.

Reserving the Adaptive Cart, Making a Tee Time and Play

- You must contact the pro shop directly by phone to reserve an adaptive cart for practice and for on course play. 308-635-2277
- Please provide at least a 3-day reservation request prior to anticipated use to ensure the cart is available and trained staff member or volunteer is available to assist with set up of cart.
- Adaptive cart is available on a first reserved first served basis and may need charging time in between rounds.
- Please be mindful of pace of play expectations at course and operating the carts on the greens in a manner that minimizes scuffing.
- We do not loan out adaptive cart outside of Monument Shadows Golf Course.

Practice Facilities

There is no charge for adaptive cart use for range, putting and chipping. Please call ahead to make sure we do not have any leagues, programs, or other scheduled play that would close these practice areas. Call the pro shop to reserve the adaptive cart for practice play.

Adaptive recreation assistance

Our golf employees are very limited in what services they are qualified to provide guests with adaptive mobility needs. We want you to have the best possible guest experience and have a staff or a volunteer available upon appointment to assist with fitting and player support. Monument Shadows Staff or volunteers are not available for transfer assistance, to the VertaCat. User is responsible for arranging assistance in transfer to the VertaCat.

Adaptive Golf Cart

45-minute information and training session for new VertaCat and ParaGolf participants.

Purpose: Monument Shadows Golf Course is committed to providing golf opportunities to individuals require mobility assistance in order to practice or play golf on the course. Because we desire for all individuals to have the opportunity to play golf we rent a VertaCat mobility cart for use on our course.

To promote a safe and fun experience for golfers using this equipment, Monument Shadows Golf Course requires each participant to complete a 45-minute information and training session with one of our staff prior to any independent use of the cart. This session will include a personal fitting and instructions for using the cart at practice areas and on the golf course. The participant will acknowledge this information by completing a series of signoff statements attesting they understand and can demonstrate safe use of the cart. Users are also required to sign a liability waiver before independently using the VertaCat.

I, _____ (Participant), acknowledge that I have been informed on the controls and safe operation of the VertaCat on _____ (Date) and understand and agree to the following items:

OR: I, _____ (Participant), **waives** this training and attest that I have been using a VertaCat, for the past _____ years and am fully informed on its safe use and operation.

Participant Must initial and sign the following items below:

I Will/Can

_____ Power cart off when any making any belt or equipment adjustments and when moving in and out of cart.

_____ Secure myself in the cart using cart belts (as applicable) – lap belt, knee belt, and chest belt.

_____ Raise and lower cart and aware of any interference from belts, clothes, golf clubs.

_____ Can stop cart quickly and in an emergency.

_____ Safely navigate cart around fixed objects and tight spaces.

_____ Demonstrate awareness of length of cart and compensate during turns and maneuvering.

_____ Reduce speed for conditions such as hills, obstacles, cars, other carts etc

_____ Change speed control to lowest setting to safely match conditions such as hills and navigating challenging spaces. Experiences slope alert on VertaCat.

_____ Anticipate and respond to slopes by reducing speed, and safely moving away from slope.

_____ Avoid uneven surfaces and slopes near water, steep bunkers, ditches, wet areas, or other areas where it is not possible to maneuver the cart.

Revised August 13, 2024

_____ Recognize and stay away from areas that are impassible or may damage the cart or cause injury to myself.

_____ Demonstrate knowledge of basic golf course etiquette and pace of play.

_____ Ask caddy or playing partner to retrieve errant golf ball shots to keep up with pace of play or to place ball in reachable and maneuverable distance to cart.

_____ Maneuver cart on green with no disturbance to turf and putting surfaces.

_____ Accept financial responsibly for any damage done to the cart while I am using it.

Signature of Participant

Mailing Address

City

State Zip

Print Name

Telephone

Date

email

Attest:

Verified _____ (participant) was **trained** or **waived** training on the VertaCat

By _____ print employee name

_____ employee signature

_____ Date

CITY OF GERING
APPLICATION FOR KENO FUNDS
(Please type application request)

Name of organization: Allred Brothers Fireworks Show Date submitted: 02/10/2026

Mailing address: 2265 17th St. Gering, NE 69341

Phone number: (308) 672-8593 Fax: Date established: 1994

Location of main office: Gering Location of local Office:

Chief operating officer's name and title: Justin Allred, Event Organizer

Organizational structure: (board of directors, executive committee, etc.)
Justin Allred, Tracie Allred, Hunter Ross, Gannon Allred, Rodney Allred & Tina Allred

Explain in detail what the keno funds will be used for: (purchasing capital, implementing new programs or a special project, not to supplement an operating budget)

See attached.

How much money are you requesting? \$8,500

Provide a copy of your annual budget. Attached

Do you receive matching funds with the support you receive from the city? Some donations from Businesses

Have you applied for keno funds before? Yes Did you receive keno funds before? Yes

Please provide a date and amount of prior funds received: 7/25 \$7,500, 7/24 \$6,000 7/23 \$5,500

List other organizations in the area that provide the same or similar services: None that we know

How many people were served last year? 3,000+ How many were repeat service?

What ages? All ages

How many were residents from: See attached Gering; Scottsbluff; Terrytown

Rural Scotts Bluff County

(Please attach an additional sheet if necessary to provide complete answers.)

Describe how your organization impacts the community:

See attached

ALLRED BROTHER'S

FIREWORKS SHOW

Dear Keno Committee,

February 10, 2026

The Allred Brother's Fireworks Show is made up of myself, my wife Tracie, other family members and close friends. Our show started back in 1994 as a family celebration but, in the last 10 years or so it has grown to a very well attended public show. We all work together and contribute over 250 hours to make this show happen.

If approved, the Keno funds will help offset \$20,000+ cost of insurance, fireworks, and other equipment for the show. We are requesting **\$8,500** from the Keno funds and will work to get another \$11,500 through other fundraising efforts. This is an increase of \$1,000 over last year but, costs continue to increase and we would like to make the 250th Anniversary a very large celebration.

The Allred Brother's Fireworks Show provides a fun, safe and enjoyable family friendly Independence Day Celebration and Fireworks Show for citizens of Gering, Scottsbluff and other surrounding communities. The Show was held at The Five Rocks Amphitheater for the first time in 2020, prior to that it was held at the Gering Football Stadium for seven years and on the Gering High School lawn for three years.

We plan to work with Valley Auto Locators again to host a Truck show at Five Rocks prior to the show with food vendors. This has grown substantially over the last few years and is turning into a great and free event for our community!

This show has always been free and open to the public and in the last few years, was the only public illuminations display in the Scottsbluff and Gering area.

In recent years we estimate that there are 3,000+ people of all ages who attend. We believe that most people who attend are from Gering and Scottsbluff but, we know there are people who come from other Nebraska communities such as; Lincoln, North Platte, Sidney and also from places like Wyoming, Colorado, Kansas and even Utah.

We are very grateful to the City of Gering and staff who help make this show possible, it would not be possible without their support!

Thank you for your interest, time and anticipated support of the celebration of our beautiful free country!

Justin Allred

ALLRED BROTHER'S FIREWORKS SHOW

2265 17th St. Gering, NE 69341

(308) 672-8593

originaljustin@yahoo.com



ALLRED BROTHERS FIREWORKS SHOW
2026 PROPOSED BUDGET
02/10/2026

PROPOSED RECEIPTS

Keno Funds	8,500.00
Local Business Donations	10,500.00
Cash Donations	1,000.00
Total Gross Receipts	<u>\$20,000.00</u>

EXPENDITURES

Advertising	1,750.00
Insurance	1,250.00
Meals	750.00
Labor, contract	2,500.00
Supplies and equipment	13,000.00
Travel, fuel	750.00
Total Expenditures	<u>\$20,000.00</u>

Balance to be Carried Forward

0.00

TOTAL

0.00

CITY OF GERING
APPLICATION FOR KENO FUNDS
(Please type application request)

Name of organization: Drive 308 Date submitted: 3/18/26
Mailing address: 2620 10th St Gering NE 69341
Phone number: 308-575-0610 Cell Number: _____ Email: valleyautolocators@gmail.com

Explain in detail what the Keno Funds will be used for: (purchasing capital, implementing new programs or a special project. Keno Funds may not be used to supplement an operating budget) _____
We were grateful to be able to purchase T-shirts last year with Keno money and will be looking to continue that this year. We would like to supplement our advertising costs and prizes for winners of the Truck Show

(Please submit a detailed explanation of the program and/or project and how Keno Funds will be used, how it applies to community betterment and who benefits from this on a separate piece of paper and email a Word file document to cmarting@gering.org)

How much money are you requesting? \$2500.00

Provide a copy of your annual budget. \$10953

Do you receive matching funds with the support you receive from the City? No
If so, who do you receive the funds from? _____

Have you applied for Keno Funds before? Yes Have you received Keno Funds before? Yes
Please provide a date and amount of prior funds received: \$2000

Describe how your organization impacts the community: _____
This will be our 6th annual Truck Show in Gering. Every year we have more and more participants and viewers. This year will be on a busy 4th of July weekend and in conjunction with the Allred Brothers Fireworks Show. We have many food vendors that come and benefit as well as hotels and restaraunts. This will attract more out of towners to provide needed tourism for area. We have attracted people in past years from Wyoming, Colorado and South Dakota. This is a great event to involve the whole family!

2026 Est	
Expenses	
Website	\$250.00
State Permit	\$53.00
Ads	\$1,300.00
DJ	\$1,000.00
Shirts	\$3,000.00
City Permit	\$800.00
Trophies	\$400.00
Posters	\$600.00
Cash Prizes	\$3,000.00
Fireworks	\$600.00
Event Supplies	\$900.00
Hotel	\$900.00
Show Truck	\$5,000
Total Est	\$17,803.00

CITY OF GERING
APPLICATION FOR KENO FUNDS
(Please type application request)

Name of organization: PVC Monument Marathon Date submitted: 3/26/2026
Mailing address: 1601 East 27th Street, Scottsbluff, NE 69361
Phone number: 308-630-6550 Cell Number: _____ Email: _____

Explain in detail what the Keno Funds will be used for: (purchasing capital, implementing new programs or a special project. Keno Funds may not be used to supplement an operating budget) _____
Expo Sponsorship- \$5,000
Native American Drummers - \$1,200
Radio Marketing - \$3,500
Targeted Marketing - \$2,500
See Attached

(Please submit a detailed explanation of the program and/or project and how Keno Funds will be used, how it applies to community betterment and who benefits from this on a separate piece of paper and email a Word file document to cmarting@gering.org)

How much money are you requesting? \$12,200

Provide a copy of your annual budget. See Attached

Do you receive matching funds with the support you receive from the City? No
If so, who do you receive the funds from? _____

Have you applied for Keno Funds before? Yes Have you received Keno Funds before? Yes
Please provide a date and amount of prior funds received: 4/2025 - \$6,000

Describe how your organization impacts the community: See Attached



WNCC Foundation 2026 Keno Funds Request

Event Overview

The **15th Annual Platte Valley Companies Monument Marathon** will take place on **September 26, 2026**, guiding runners through the breathtaking landscape of Western Nebraska—from the Wildcat Hills State Recreation Area, through Mitchell Pass along the Oregon Trail, and around Scotts Bluff National Monument. The event features a full marathon, half marathon, and 5K.

Since its inception, the Monument Marathon has remained focused on promoting healthy lifestyles, showcasing the beauty and history of Western Nebraska, generating local tourism revenue, and raising vital funds that support Western Nebraska Community College students.

Community Impact

Support for WNCC Students

The Monument Marathon is the WNCC Foundation's largest annual fundraiser. All proceeds stay in the community and directly support:

- Student scholarships
- Emergency assistance
- Academic and student success programs
- Capital projects and programmatic initiatives

During the 2025–26 academic year alone, more than **350 scholarships totaling over \$315,000** were awarded. Since 2012, the Marathon has generated **over \$717,000** to support WNCC students. The economic benefits extend locally as well, as the event prioritizes contracting with Western Nebraska vendors for shirts, printing, photography, videography, and supplies.

Tourism & Economic Benefits

The 2025 race achieved record participation with **669 registered runners**, an 11% increase over 2024. Notably:

- **77%** of runners traveled from outside Scotts Bluff County
- Participants represented **41 states, 246 cities**, and even included runners from **Kenya and Peru**
- Nearly half brought **2–5 additional guests**
- Over **58% stayed at least one night**, with increases in hotel, Airbnb, and campground stays

These visitors bring tourism dollars directly into local restaurants, lodging, shops, and attractions. In 2025, **66% of participants were first timers**, demonstrating strong marketing reach and ensuring continual growth.

For 2026, the goal is to raise participation to **700 runners**, continuing steady expansion while replacing the roughly 60% new-runner turnover common in large destination races.

Funding Needs for 2026

To reach these goals and strengthen the economic and cultural impact of the event, the WNCC Foundation requests support from the Gering Keno Committee for the following priority areas:

1. Expo Sponsorship Upgrade – \$5,000

We respectfully invite the Gering Keno Committee to consider becoming the **2026 Monument Marathon Expo Sponsor**, in partnership with the Gering Civic Center. More than **600 runners and their family/friends** pass through the Expo each year, making it one of the most visible sponsorship opportunities.

Sponsorship highlights include:

- Prominent inclusion on Expo materials and event T-shirts
- Logo placement on the Monument Marathon website and digital promotions
- Recognition at the Expo and on race day
- The option to host a vendor table and include materials in runner bags
- Up to **4 complimentary entries** plus **50% employee discounts**

This upgrade enhances the City of Gering's connection to one of the region's most recognized and celebrated events.

2. Targeted Digital Marketing – \$2,500

The Monument Marathon relies on a robust digital strategy to reach runners nationwide. Two of the most effective tools used are **targeted advertising** and **Google remarketing**.

What Google Remarketing Is (and Why It Works)

Google remarketing allows us to display Marathon ads specifically to people who have already interacted with our website, event pages, or similar running-related content online. For example, if someone explores our course map or registration page but doesn't sign up right away, remarketing ensures they later see ads reminding them to register while they browse YouTube, Google, or partner sites. Other running events can also be geo-fenced so their participants will receive our ads.

This makes our marketing:

- **Highly efficient**, because it targets people who already showed interest
- **Cost-effective**, since ads are served only to relevant users
- **Successful in driving conversions**, which has contributed to a **25% growth in registrations from 2023 to 2025**

Keno funds will help us expand this proven digital outreach and stay competitive with larger regional and national races.

3. Native American Drummers – \$1,200

One of the most memorable and meaningful traditions of the Monument Marathon is the performance by **Native American drummers** in the final stretch of the race. Their rhythm encourages runners as they approach the last hill and reflects the cultural heritage of our region.

Funding will cover performance fees, travel, and lodging to ensure this distinctive and well-loved element continues. Many runners report that this powerful moment is one of the most unforgettable aspects of the event.



4. Local & Regional Radio Advertising \$3,500

While the Monument Marathon attracts runners nationwide, maintaining strong **local engagement** is essential. Roughly **one-third** of participants live within 100 miles, and more than **300 volunteers** are needed each year to support runner safety, aid stations, and logistics.

Keno support will strengthen:

- Local radio advertising
- Regional Nebraska radio promotion
- Volunteer recruitment messages

This ensures local residents remain connected to the event and encourages regional participation.

Conclusion

The WNCC Foundation and Monument Marathon Steering Committee are deeply grateful for the Gering Keno Committee's ongoing support. Your investment helps strengthen:

- Local tourism
- Community engagement
- Cultural experiences
- Student success at WNCC
- Regional visibility for Western Nebraska

We look forward to the opportunity to partner with you again in 2026 and to continue showcasing Gering as a key part of this premier Nebraska event.

The map below represents our regional marketing target area. Our Google targeted /remarketing and social media ads reach across the United States. It also focuses on the participants of major races across the country.

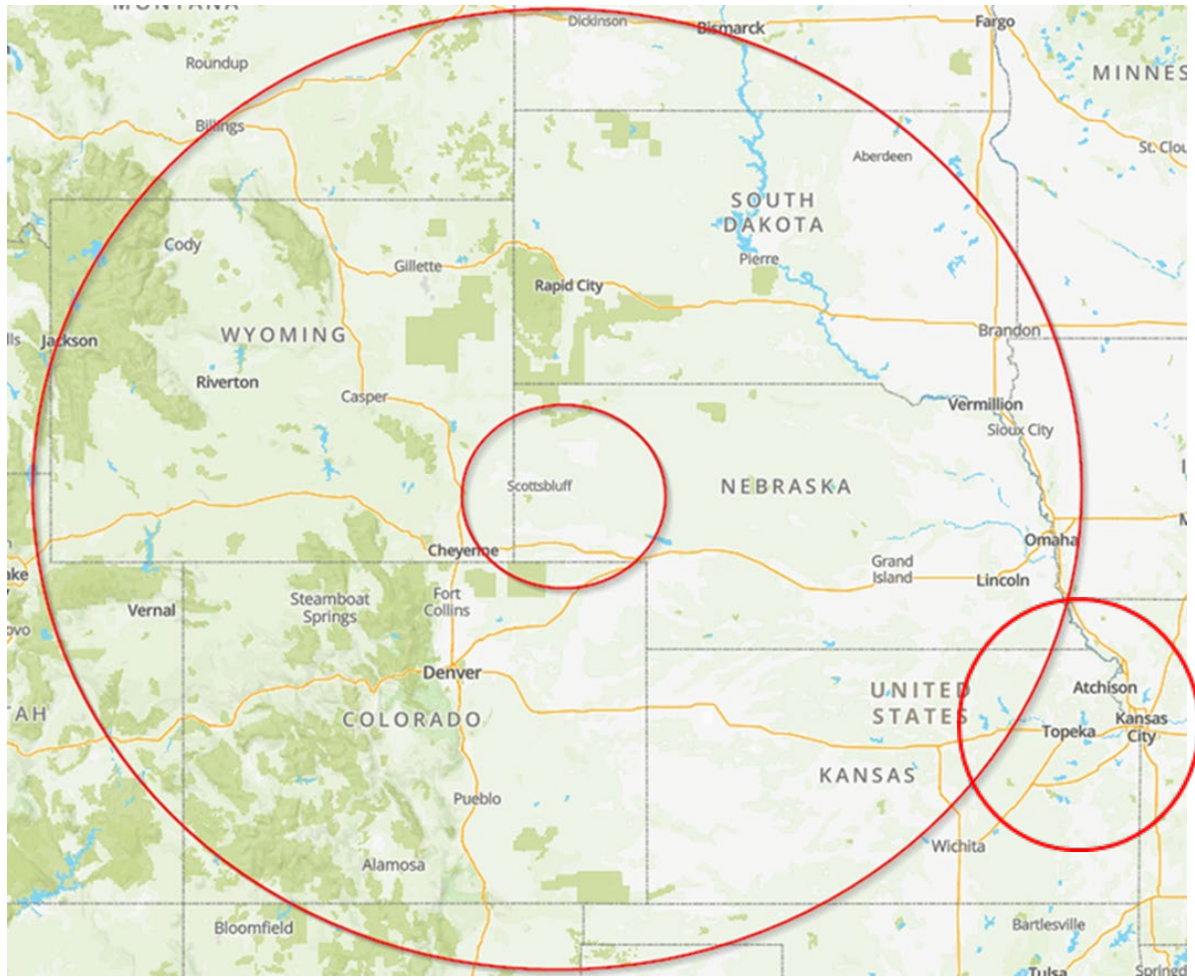

Video Link: <https://www.sheepcreekfilms.com/monument-marathon-2022>



2026 Monument Marathon Expense Budget

Category	2026 Budget	2026 Grants Requested	Amount Awarded
Star-Herald Local Marketing	\$ 2,000.00		
YouTube and Other Audio Ads (Podcasts)	\$ 1,000.00	SBAVB	
Social Media Outside Area	\$ 2,500.00	City of SB	\$2,500.00
Targeted Marketing (including Feathr)	\$ 12,000.00	SBAVB	\$6,000.00
		City of SB	\$3,500.00
		Gering Keno	
Colorado Runner Emails	\$ 2,000.00	SBAVB	\$2,000.00
Local/Regional Radio Ads	\$ 3,500.00	Gering Keno	
	\$ 23,000.00		
NE Tourism Web Ads	\$ -		
NE Travel Guide/Qtly Banner/E-letter bundle	\$ 5,500.00	NE Tourism	\$4,125.00
Western Nebraska Travel Magazine	\$ 700.00	SBAVB	
	\$ 6,200.00		
New Expo Lodging & Travel	\$ 700.00		
New Expo Registration	\$ 600.00	SBAVB	
	\$ 1,300.00		
Sheep Creek Films	\$ -		
Website Maintenance Fee	\$ 500.00		
Save the Date Magnet & Postcards	\$ 500.00	SBAVB	
	\$ 1,000.00		
Total Marketing budget		\$31,500	
USA Track & Field	\$ 850.00		
Participant shirts	\$ 6,500.00	Gering Occ. Tax Fund	
Volunteer Shirts	\$ 3,000.00	Gering Occ. Tax Fund	
Medals	\$ 3,500.00		
Race Bibs	\$ 700.00		
Pasta Feed	\$ 3,200.00		
Canal Road Repair	\$ -		
Highway Coning	\$ 3,500.00		
Timing Company, incl. hotel	\$ 4,000.00		
Pacing Company, incl. hotel	\$ 3,500.00		
Photographers	\$ 2,000.00		
NPS Permit	\$ 50.00		
Porta Potties	\$ 2,000.00		
Native American Drummers, incl. hotel	\$ 1,200.00	Gering KENO	
Hotels - others	\$ -		
Other contracted vendor payments	\$ 300.00		
	\$ 34,300.00		
Aid Station Supplies	\$ 1,000.00		
Runner Awards/Sponsor Gifts	\$ 800.00		
Prize Money	\$ 12,750.00		
Items to sell	\$ 1,500.00		
Misc. Supplies	\$ 2,000.00		
	\$ 18,050.00		
Personnel			
Summer Intern	\$ 5,300.00		
	\$ 5,300.00	City of Scottsbluff	\$5,000
Overall Expense Budget	\$ 89,150.00		

CITY OF GERING
APPLICATION FOR KENO FUNDS
(Please type application request)

Name of organization: ESU 13 **Date submitted:** 4-01-26

Mailing address: 4215 Avenue I, Scottsbluff, NE 69361

Work number: (308) 635-3696 **Cell Number:** (308) 641-5254 **Email:** dreinhardt@esu13.org

Explain in detail what the Keno Funds will be used for: (purchasing capital, implementing new programs or a special project. Keno Funds may not be used to supplement an operating budget)

This request for KENO funds will support a free 2.5-day summer transition camp for twenty high school students (grades 10–12+) in Special Education across the Nebraska Panhandle. The camp will introduce students to careers in the carpentry trades through a hands-on construction project. Partnering with the WNCC Construction Trades Program, students will build (10) 2x4 standing flower boxes. The completed flower boxes will be donated to 2 local non-profits (CAPstone Child Advocacy Center and Housing Partners of Western Nebraska)—to assist with community beautification. Due to a rigorous schedule and potential travel time to Scottsbluff, campers will stay overnight at the WNCC dorms. If awarded, the KENO funds will be used to cover the cost of the soil for standing flower boxes as well as two nights of housing at the WNCC dorms for 20 students and two staff members.

(Please submit a detailed explanation of the program and/or project and how Keno Funds will be used, how it applies to community betterment and who benefits from this on a separate piece of paper and email a Word file document to cmarting@gering.org)

How much money are you requesting? \$802.00

Provide a copy of your annual budget. (See below)

Do you receive matching funds with the support you receive from the City? No

If so, who do you receive the funds from? N/A

Have you applied for Keno Funds before? No **Have you received Keno Funds before?** No

Please provide a date and amount of prior funds received: N/A

Describe how your organization impacts the community:

In 1965, ESU's were created to provide supplementary services to public school districts. ESU 13 specifically supports 21 school districts in the Nebraska Panhandle, also serving as strong advocates for both schools and parents. Within the SPED department, we provide transition services beginning at age 14 to prepare students for life after graduation. We focus on four core areas: post-secondary education and training, employment, independent living, and community engagement.

Thank you Gering KENO committee for your consideration of this project. Your investment would provide an opportunity to host a meaningful summer camp that will make a difference in the lives of students with disabilities in the panhandle.

Diane Reinhardt
(308) 641-5254

Please submit a detailed explanation of the program and/or project and how Keno Funds will be used, how it applies to community betterment and who benefits from this on a separate piece of paper and email a Word file document to cmarting@gering.org)

For the past five years, I have coordinated summer transition camps for students in special education. Until this year, these camps were consistently funded through a grant; however, on March 20th, I was informed that our proposal for this year's summer camp was not approved. This is a critical gap to fill, as the majority of students who attend these camps do not have the financial means to participate otherwise.

This camp will provide students with a realistic, hands-on introduction to the carpentry trade that can spark a lifelong interest in a high-demand career. Students will learn valuable employment skills like time management, accountability, teamwork, respect, communication, and leadership. Since many of our students struggle with socialization, camp provides a supportive space for them to build confidence and make new friends with students from different school districts across the Panhandle. It also gives students a chance to learn in an environment outside of their school setting and offers a unique opportunity to build independence by staying in the dorms. I strongly believe that volunteerism and community service need to be taught, with the hope that these experiences help students realize the importance of giving back to their community when they become adults.

BUILD and BLOOM TRANSITION SUMMER CAMP

This summer camp will be offered to students across the panhandle of Nebraska and will take place June 9-11, 2026. The scheduled activities will take place on the campus of WNCC, specifically the Harms Center and the WNCC Eakes Building in Scottsbluff, Nebraska, in addition to Peaceful Prairies Nursery in Mitchell, Nebraska. Due to a rigorous schedule and potential travel time to Scottsbluff, campers will stay overnight at the WNCC dorms, with 24 hour supervision, provided by two staff, for a period of two overnights. Two additional staff will assist with the camp during the daytime and evening hours.

This camp is open to high school students, in grades 10th- 12+ that are in an educational program for the 2026-2027 school year. Eligible students are those students who are verified for and receive special education services. To ensure the highest standards of safety and individualized instruction, this camp is capped at 20 students.

Days 1 through 3 of "Build and Bloom" will include traditional classroom-style presentations, however, the majority of the camp will take place at Peaceful Prairies Nursery and WNCC's Eakes building sites where students will engage in hands-on activities.

June 9th, Day 1: Camp will begin at 10:00am. Upon arrival at the Harms Center (Room E194) , students will receive a folder which will contain the camp schedule, staff contact information, and information on the WNCC Trades programs. The day will begin with an icebreaker, providing an opportunity for campers and staff to acquaint themselves with one another. After the icebreaker, staff will go over the schedule for the 2.5 day camp and answer any questions the campers may have. Staff will state their expectations of the campers in following the rules. From 10:30-11:30pm WNCC Construction Trades Instructor, Eric Anderson introduce students to the carpentry trade program at WNCC, showcasing how carpentry and construction provide well-paying career opportunities for those who excel at hands-on learning and want to jump start their career without a four year degree. From 11:30am until noon, students will learn about the non-profit organization(s) that will be receiving the standing flower boxes and how these organizations impact the community.

After lunch, the students and staff will travel to Peaceful Prairies Nursery, in Mitchell, Nebraska where they will spend an afternoon job-shadowing the staff to gain insight into the operational "ins and outs" of a professional greenhouse. Students will receive guidance on regional horticulture, learning which plants and vegetables are best suited for their flower/garden boxes. The afternoon of Day 1 will conclude with dorm room assignments (determined prior to camp by the project coordinator). After supper, students will walk back to the Harms Center and work with Cassie Behnke, VALTS instructor, to design dedication plaques, using the Glowforge 3D laser cutter/engraver. The plaques will be placed on the completed flower/garden boxes. Students will walk back to the WNCC dorms at 8:15pm and spend the remainder of the evening socializing.

June 10th, Day 2: At 8:45am the staff and students will travel to WNCC's Eakes building site. Trades Instructors, Eric Andersen and Jason Schwary, will guide students through the essentials of the carpentry trade, ranging from safety and material identification to the practical skills of reading blueprints and operating hand and power tools as students build standing flower/garden boxes. To maximize hands-on experience, students will work in pairs, ensuring each camper has direct involvement with the project. Students will have a one hour lunch break at noon. At 1pm the students will continue with the building of their flower/garden boxes until 3:45pm. Students will travel back to the WNCC dorms where they will write thank you notes to the people that volunteered their time assisting with camp. From 4:30-6pm students will eat dinner and have free time. At 6pm, students and staff will travel back to the Eakes building to plant the flowers/vegetables into their finished boxes. Students will return to the dorms at 8:15pm and will have the remainder of the evening to socialize.

June 11th, Day 3: After breakfast, students will travel to the Harms Center and complete a survey regarding their experiences and opinions of the camp and the things they learned. At 9:00am students will travel to the Eakes building to pick up the flower/vegetable boxes and

deliver them to the non-profit organizations. After the boxes have been delivered, students will return to the Harms Center. Camp will conclude at 11:30am.

The following goals have been established for the Build and Bloom camp:

Goal 1: Career Pathing in the Construction Trades

Goal 2: Develop workplace readiness skills through a hands-on construction project.

Goal 3: Develop workplace readiness skills through problem solving, while on the job site and learn how to manage the tasks necessary to finish the project. Enhance leadership skills through project management and decision making.

Goal 4: Promote workplace readiness skills through the understanding of workplace values and ethics.

Goal 5: Workplace Exploration in Ag/Horticulture

Goal 6: Foster a sense of community and contribution through a meaningful project.

Line Item Budget

Category	Line Item	Total
Personnel	Diane Reinhardt and Keagan Heilbrun (day and overnight staff) 52 hrs each @ \$25/hr	\$2600.00 (other funding source)
Personnel	Jill Trautman and Damien Zuniga (day and evening camp staff) 33 hrs each @ \$25/hr	\$1650.00 (other funding source)
Personnel	Payroll tax for 4 employees \$4250 * 7.65%	\$325.13
Personnel	Retirement benefits for 4 employees \$4250 * 8.08%	\$343.40
Personnel	WNCC Participation and Instruction & use of Eakes Building	In Kind
Supplies	Flowers/Vegetables from Peaceful Prairies Nursery Estimated at \$40 per bed x 10	\$400.00

Supplies	Planting Soil for 10 beds (Rock Pile, Gering)	\$130.00
Supplies	2x8 Plate (plaque for engraving) \$15 each x 10	\$150.00
Supplies	Building Materials for 2x4 Standing Flower Beds made of western red cedar - as determined by Eric Anderson, WNCC Trades Instructor \$220 each x 10 Quote from ZM Lumber, Scottsbluff	\$1,973.91
Other	WNCC Dorm Rates \$15.00 per night x 2 nights per student (\$30 x 20 students=\$600.00) Double occupancy \$18.00 per night x 2 nights (\$36 x 2 staff= \$72.00) Cleaning fee waived.	\$672.00
TOTAL	(2) Breakfast, (2) Lunch, (2) Supper for 20 campers and 4 staff	Donated
TOTAL		\$8244.44

Thank you KENO committee for your consideration of this project. Your investment would provide an opportunity to host a meaningful summer camp that will make a difference in the lives of students with disabilities in the panhandle.

Diane Reinhardt
(308) 641-5254

CITY OF GERING
APPLICATION FOR KENO FUNDS
(Please type application request)

RECEIVED APR 03 2026

Name of organization: SCOTTS BLUFF COUNTY CERT Date submitted: APRIL 3, 2026
Mailing address: 2405 AVE B, SCOTTSBLUFF NE 69361
Phone number: 308-631-1977 Cell Number: 308-765-3322 Email: Track.SEEKR@gmail.com
Who is the check to be made out to: SCOTTS BLUFF COUNTY CERT

Explain in detail what the Keno Funds will be used for: (purchasing capital, implementing new programs or a special project. Keno Funds may not be used to supplement an operating budget) CERT USES RADIOS DURING PUBLIC EVENTS, ASSISTANCE TO LAW ENFORCEMENT, ASSISTANCE TO FIRE DEPARTMENTS, COUNTY & CITY EVENTS DURING SEARCHES, FIRST AID, REHAB SITUATIONS, TRAFFIC CONTROL & OTHER FORMS OF PUBLIC ASSISTANCE, AND WE HAVE ACQUIRED RADIOS TO USE & THE BATTERIES ARE NEEDING REPLACED & MISSING CHARGERS.
(Please submit a detailed explanation of the program and/or project and how Keno Funds will be used, how it applies to community betterment and who benefits from this on a separate piece of paper and email a Word file document to cmartin@gering.org)

How much money are you requesting? \$2,818.16

Provide a copy of your annual budget. WE DON'T HAVE/USE AN ANNUAL BUDGET.

Do you receive matching funds with the support you receive from the City? HOPEFULLY YES
If so, who do you receive the funds from? SCOTTSBLUFF CITY KENO FUNDS

Have you applied for Keno Funds before? YES? Have you received Keno Funds before? YES?
Please provide a date and amount of prior funds received: MAYBE AROUND 12-16 YRS AGO IN SCOTTSBLUFF.

Describe how your organization impacts the community: CERT IS A VOLUNTEER ORGANIZATION & FALLS UNDER CITIZEN CORP OF EMERGENCY MANAGEMENT. WE RESPOND TO REQUESTS & CALLOUTS FROM LAW ENFORCEMENT, FIRE DEPARTMENTS, COUNTY & CITY DEPARTMENTS TO HELP WITH TRAFFIC CONTROL, PERIMETER CONTROL, FD & LE REHAB, DISASTOR ASSISTANCE, BASIC FIRST AID, SEARCH & RESCUE OF MISSING PERSONS. ALL WITH THE BACKGROUND PURPOSE TO RELIEVE TRAINED PROFESSIONALS OF DUTIES WE CAN HANDLE.

Gering City Keno Committee,

CERT stands for Community Emergency Response Team. It was developed in 1985 in California after a massive earthquake, to provide trained volunteers to help Law Enforcement and Fire Departments with duties to free up the professionals, so they can do what they need to do. It falls under the Citizen Corps of Emergency Management. Locally, our CERT team was started around 2004 by Bob Hessler, and today we have a team of 42 members, and one of the best in the State of Nebraska. Our members are all volunteers and come from different backgrounds, such as EMS, FD, LE, military, technicians, clergy, students, extension agents, postal workers, maintenance, construction, office and banking, retired, mothers, fathers, and more. About half of our team has over 15 years invested. We train once a month, plus occasional field callouts to train. We train on basic fire suppression, first aid, fire fighter rehab, supplying meals to Fire and Law personnel during long term events, controlling a perimeter for a crime scene, an evidence search, and structure fires, traffic control, disaster psychology, missing persons search, man-tracking, assisting K9 teams, assisting with water rescue, sonar searches, reports and scribing, and dealing with human mindsets present on their worst day. Everyone on the team has to pass an LE background check, follow guidelines when representing this team and the public. Scottsbluff Police Department is our sponsor and has the final say on whether we respond to a request to help.

We offer assistance to our local LE and Fire Departments when they request it. We also participate in events such as the Monument Marathon, Horizon's Music Festival, County Fair events, Balloon Glow, Gravel Grind Bike Race, Beans Beef and Bluegrass, Oregon Trail Days and others that may need extra eyes watching the crowd, and/or first aid stations.

CERT does not use or have an annual budget, and the money we have in the bank is from dues for purchasing water, snacks and other needs of the members. The equipment we have and use is normally donated. We currently use radios that have been provided for us to use, because departments have upgraded their radio equipment and by the time we get them, the batteries are normally spent and sometimes the chargers and/or other accessories have been lost or are faulty. CERT very much appreciates the radios provided for use and they allow us more timely responses and operations in the field. This is the reason we are approaching the

Keno Committee for some funding to purchase batteries and chargers to keep using the radios.

I appreciate the consideration and your time. If you have any more questions, please contact me.

Thank You and Best Regards;

Larry Martin

308-631-1977c

308-765-3322w

track.seekr@gmail.com

CITY OF GERING
APPLICATION FOR KENO FUNDS
(Please type application request)

Name of organization: Oregon Trail Days Date submitted: _____
Mailing address: P O Box 334 Gering NE 69341
Phone number: _____ Cell Number: 308-641-4018 Email: otdgering@gmail.com

Explain in detail what the Keno Funds will be used for: (purchasing capital, implementing new programs or a special project. Keno Funds may not be used to supplement an operating budget) _____
Oregon Trail Days will be bringing a concert and need help with some of the expenses.
We have narrowed down what we are doing for the Old Settlers and would like help this year towards the luncheon.

(Please submit a detailed explanation of the program and/or project and how Keno Funds will be used, how it applies to community betterment and who benefits from this on a separate piece of paper and email a Word file document to cmarting@gering.org)

How much money are you requesting? _____

Provide a copy of your annual budget. Attached _____

Do you receive matching funds with the support you receive from the City? NO
If so, who do you receive the funds from? _____

Have you applied for Keno Funds before? Yes Have you received Keno Funds before? _____
Please provide a date and amount of prior funds received: 2024 received around \$3929.30 and
2025 received around \$4099.90

Describe how your organization impacts the community: Please see attached

Concert

Food/Drink/Meals	\$ 700.00
Lodging	\$ 900.00
Security	\$ 1,250.00
Ground Transportation	\$ 750.00

Old Settlers

Fruit and Vegetable Trays	\$ 500.00
---------------------------	-----------

\$ 4,100.00

Cash Flow - Last year

1/1/2025 through 12/31/2025

4/3/2026

Page 1

Category	1/1/2025- 12/31/2025
INFLOWS	
Art Show Income	33,345.48
Artist Commission	-23,931.84
Mailings	-146.00
Reception Night	-154.13
Ribbons	-117.46
Seed Money	-286.00
State Income Tax	-2,628.09
TOTAL Art Show Income	6,081.96
Car Show Income	630.00
Donation	400.00
Entertainment	-200.00
Plaques	-53.75
Posters	-80.63
T-Shirt Sales	-215.00
TOTAL Car Show Income	480.62
Carnival Income	18,000.00
Ice	-1,654.00
Parking	-540.00
Port-A-Potties	-1,550.00
TOTAL Carnival Income	14,256.00
Chili Cook Off Income	3,985.00
Beer Garden	3,524.61
Entertainment	0.00
Golf Carts	-240.00
ID checks	-300.00
Park Rental	-593.40
Participant Prizes	0.00
Port-A-Potties	-400.00
Seed Money	0.00
Supplies	-656.53
Tents	-2,006.25
TOTAL Chili Cook Off Income	3,313.43
Concert	-23,434.23
Advertising	-4,068.00
Beer Garden	250.00
Entry Gate Help	-1,100.00
Golf Carts	-60.00
Ice	265.00
Security	-1,000.00
Supplies	-65.04
Ticket Sales	38,178.00
TOTAL Concert	8,965.73
Craft Show Income	3,815.00
DJ	0.00
Golf Carts	-60.00
Miscellaneous Expense Craft Show	-198.77
Port-A-Potties	-75.00
Security	-300.00
TOTAL Craft Show Income	3,181.23

Cash Flow - Last year

1/1/2025 through 12/31/2025

4/3/2026

Page 2

Category	1/1/2025- 12/31/2025
Donations To Oregon Trail Days	4,500.00
Food Fair Income	4,510.00
Picnic Tables	-300.00
Port-A-Potties	-150.00
TOTAL Food Fair Income	4,060.00
Horse Shoes	520.00
Plaques	-64.50
Pole Tents	-401.25
Port-A-Potties	-75.00
TOTAL Horse Shoes	-20.75
Interest Inc	1,925.26
Keno Requests	-460.47
Kiddie Parade	-428.34
Monument Mile	200.00
Mud Volleyball Income	6,348.00
1st Place Prizes	-258.00
Beer Garden	528.26
DJ	0.00
Golf Carts	-60.00
Port-A-Potties	-375.00
Supplies	-229.53
T-Shirts	-3,752.23
Tents	-401.25
TOTAL Mud Volleyball Income	1,800.25
Parade Income	
Dignitary Tea	-209.63
Golf Carts	-180.00
Marching Band	-500.00
Port-A-Potties	-75.00
TOTAL Parade Income	-964.63
Parking at Five Rocks	0.00
Pickleball	71.00
Quilt Show	498.29
Safe Ride	
Donations	1,000.00
Fuel Cards	-1,000.00
TOTAL Safe Ride	0.00
TOTAL INFLOWS	47,459.58

OUTFLOWS

Advertising	
Brochure	-819.58
Posters	-275.94
Radio	600.00
Website	279.20
TOTAL Advertising	-216.32
Auto & Transport	
Registration	85.20
Service & Parts	23.54
TOTAL Auto & Transport	108.74
Bills & Utilities	

Cash Flow - Last year

1/1/2025 through 12/31/2025

Category	1/1/2025- 12/31/2025
Utilities	
Electric And Sanitation	1,164.25
Gas	879.00
Internet And Telephone	898.91
TOTAL Utilities	2,942.16
TOTAL Bills & Utilities	2,942.16
Fees & Charges	
SDL	100.00
TOTAL Fees & Charges	100.00
Food & Dining	
Doughnuts	30.44
Restaurants	200.51
TOTAL Food & Dining	230.95
Insurance	
Auto Insurance	180.46
Board Members	1,039.00
General Liability	2,328.50
TOTAL Insurance	3,547.96
Office Supplies	796.48
OTD Building Repairs	405.00
Payroll	861.98
Taxes	
Corporate Registration	41.40
TOTAL Taxes	41.40
USPS	192.00
TOTAL OUTFLOWS	9,010.35
OVERALL TOTAL	38,449.23



Oregon Trail Association

PO Box 334 – Gering Nebraska 69341-0334

April 5, 2026

A. Description of Existing Event

Oregon Trail Days is Nebraska's oldest continuous celebration honoring all old settlers to the area. Now in its 105th year providing family entertainment to an estimated 38,000 people at various venues throughout Gering, the mid-July event unites the entire tri-city community through the presentation of twenty-five separate activities over four days. Grants, donations, and sponsorships alleviate cost and allow activities to be available to all ages and economic ranges.

Oregon Trail Days benefits Scotts Bluff County by creating encouragement to both former residents and potential tourists to attend the event, purchasing lodging, food, and fuel in the process. Additional Scotts Bluff County entities have the opportunity to promote their own agenda, encouraging attendance at future events.

In 2025, twenty-five foundations, companies/firms, individuals, and others co-sponsored Oregon Trail Days by contributing \$250 to \$1,000.

The target market is everyone with emphasis on honoring the Old Settlers and descendants of pioneers of the area. Every age group is included in activities from the kiddie parade to the Old Settlers gatherings. Grants and sponsorships permit many activities to be free, allowing every financial level to participate.

Zip codes can be recorded for participants (not spectators) of events with registrations. These include the Vera Dulaney Memorial Art Show, International Food Fair, Chili Cook-off, Mud Volleyball, Rod and Custom Car Show, and Horseshoe Tournament. Obviously, zip codes of spectators cannot be obtained.

Oregon Trail Association has applied for funds previously from Scotts Bluff County Tourism Committee and/or Scotts Bluff Area Visitors Bureau. We have not received Tourism funds the past 2 years.

There is a four-point plan for becoming financially sustainable. Depending on the economic barometer at the time, Oregon Trail Association must consider expanding its donor base, increasing participation fees, lowering number of activities, and/or possibly lessening efforts

toward free activities or those activities with a poor income to outgo ratio. Self-sufficiency will become more difficult as years go by due to continually increasing costs spread over a continually declining population base, and these factors must be scheduled into a financially sustainable plan.

B. Detailed Marketing Plan

The plan to attract visitors from over one hundred miles away includes use of the local Star-Herald newspaper and Nspire Today! regional publication as both service areas over 100 miles distant (Chadron, Ogallala, Cheyenne). Also, the Star-Herald may be used as a resource to secure advertising in outlying areas through newspapers primarily serving neighboring areas of a 100-mile radius. Additionally, use of Rural Radio Scottsbluff will be utilized as its signal surpasses the 100-mile mark in every direction; Rural Radio Scottsbluff, KNEB, will be contacted regarding advertising over its sister station, KRVN, of Lexington, Nebraska. In this manner local media and their affiliates will be utilized to reach a larger market.

Marketing Budget

Promotional Merchandising	\$ 7,553.00
Print Media	4,247.00
Audio Promotion	2,500.00
Website Maintenance	<u>700.00</u>
Total	\$ 15,000.00

For most items constituting the Marketing Budget, vendors (local preferred), quantities, and designs have yet to be determined at the time of submission of this grant application.

C. Proposed Impact of Promotion

Scotts Bluff County can expect up to 40,000 people scattered over a four-day period (or longer, if they so choose) expending funds for lodging, food, and fuel. A survey in 2022 showed 180 room-nights were rented at Microtel Inn and Suites, 155 room-nights at Cobblestone Inn and Suites, and 136 space-nights rented at Robidoux RV Park, all of which were attributed to Oregon Trail Days. Just those three facilities totaled 471 room- and space-nights; based on the 2022 \$10,000 grant, that figures to \$21.23 room- and space-night, a quite low figure for that statistic. The amount of lodging tax collected due to Oregon Trail Days could be calculated but would be an extensive project as three of a minimum of twenty-four known facilities generated 471 room- and space-nights during the 2022 event alone. With a proven potential of 40,000 guests, a \$10,000 grant to entice visitors breaks down to a cost of a quarter for every individual.

A not unduplicated count of 37,854 individuals was calculated in numbering attendees at Oregon Trail Days in 2022.

Oregon Trail Association emphasizes staying for the duration of the event through listing all events on the quadrifold, our most extensive marketing tool. Interviews and presentations also tell of multi-day stays for event participation.

Gering venues to be utilized by Oregon Trail Days include Five Rocks Amphitheater, Gardner Park, Gering Civic Center, Gering High School, Grasslands, Legacy of the Plains Museum, Legion Park, Lincoln Elementary School, Oregon Trail Park, Scotts Bluff National Monument, and Tenth and other Gering streets.

Comments heard and stories told indicated many first-timers to Oregon Trail Days from outlying areas intended to not only return to a future Oregon Trail Days celebration but also encourage bringing family and friends with them. Other impressed first-timers strategically visited local friends/family to participate in Oregon Trail Days. Arizona-based Frazier Shows Carnival pumps thousands of dollars into the area economy through the purchase of trucks, equipment, parts, and repairs as the owner has developed a favorable relationship with local vendors. All have a positive impact on Scotts Bluff County promotion and economic growth.

D, Dates of Promotion

Promotion of Oregon Trail Days for 2026 began the first of 2026 and will continue through the Sunday July 12, 2026. The dates for which the event is being promoted is July 9-12, 2026.

E. Proposed Locations of Advertising

Advertising is proposed throughout Nebraska, Eastern Wyoming, and Northeastern Colorado.

CITY OF GERING
APPLICATION FOR KENO FUNDS
(Please type application request)

Name of organization: Old West Balloon Fest Date submitted: April 6, 2026

Mailing address: P. O. Box 251, Mitchell, NE 69357

Phone number: 308-225-0128 Cell Number: Same Email: colleenjohnson302@gmail.com

Explain in detail what the Keno Funds will be used for: (purchasing capital, implementing new programs or a special project. Keno Funds may not be used to supplement an operating budget) _____

The funds will be used to provide hotel accommodations for US National pilots and staff in Gering. Please see the attached document for additional information.

(Please submit a detailed explanation of the program and/or project and how Keno Funds will be used, how it applies to community betterment and who benefits from this on a separate piece of paper and email a Word file document to cmarting@gering.org)

How much money are you requesting? \$10,000

Provide a copy of your annual budget. Please see attached

Do you receive matching funds with the support you receive from the City? Yes

If so, who do you receive the funds from? City of Scottsbluff, City of Mitchell, Village of Morrill, City of Terrytown, Scotts Bluff County Tourism.

Have you applied for Keno Funds before? Yes Have you received Keno Funds before? Yes

Please provide a date and amount of prior funds received: _____

We have received funds from 2015 to the present. We have received between \$6,000 and \$10,000 each year.

Describe how your organization impacts the community: Please see attached



Overview:

Our mission is to create a joyful experience for patrons of all ages with a family-friendly, all-inclusive community event. The Old West Balloon Fest is a world-class event that brings pilots and visitors from across the United States and Foreign countries to Scotts Bluff County, Nebraska. This year marks our 12th Anniversary Celebration, and we've added many fun and exciting activities to the lineup.

Showcasing Our Area

The Old West Balloon Fest is more than a weekend event — it has become one of the strongest community-building traditions in our region. Every year, thousands of residents and visitors come together to share something joyful, safe, and uniquely ours. Families, seniors, schools, volunteers, and local businesses all benefit from the energy and tourism generated by the event.

Last year alone, the festival generated significant economic activity for our hotels, restaurants, and retailers. It also provided free programming for the public — including balloon launches, kids' activities, STEM/aviation education, and community nights that bring people together. These experiences are only possible because of partnerships like yours.

The Old West Balloon Fest has designated the Gering Civic Center as the headquarters for the U.S. National Hot Air Balloon Championships. In accordance with our contract with the Balloon Federation of America, all pilot and staff lodging must be located within a five-minute drive of the headquarters. The Civic Center will serve as the site for the master pilot briefing on August 9, 2026, as well as all morning and evening briefings throughout the event. To meet lodging requirements, we have secured the entire Monument Inn and Suites, reserved 20 rooms at Hotel 21, and an additional 25 rooms at the Cobblestone Inn and Suites. This approach ensures that the majority of lodging tax generated by Championship participants will remain within the City of Gering.

Positioning the discovery exhibit in Gering for the majority of the event further supports local economic activity by encouraging visitors to spend time and money at nearby retail businesses and restaurants.

The Old West Balloon Fest showcases our region by attracting visitors from surrounding states such as Colorado, Wyoming, South Dakota, Kansas, and Eastern Nebraska. In 2025, we tracked visitor attendance, revealing that visitors attended from 34 states, Mexico, and Canada, and one visitor from the UK. Visitor attendance was tracked by using the parking pass sales online and by capturing license plate numbers from attendees at the event. By hosting an opening ceremony, we ensure that multiple night stays will take place in Gering, as visitors will attend the ceremonies and additional days of competition. Visitors will need to spend the night in order to attend early morning activities taking place at 6:00 AM. We look forward to the following three years hosting the US National Hot Air Balloon Championships 2026-2028. We know this event will attract many new visitors to our area.

Gering will have the opportunity to generate significant media exposure and strengthen community pride by promoting its role as the headquarters for the National Championships. The nationally recognized YouTube television show “My Town” is scheduled to film during the event, providing exceptional visibility for the City of Gering and the broader Western Nebraska region. Our marketing strategy is designed to attract visitors and encourage multi-night stays, giving guests time to explore the area and enjoy its many attractions. The Nebraska Tourism Office actively supports and promotes the event through social media at VisitNebraska.com, as well as through advertisements, articles in Nebraska Life, banner ads on their website, and a feature in the 2026 Nebraska Visitors Guide.

Lodging tax collections are expected to be maximized, with Gering hotels projected to reach 99 percent occupancy during the event. Sales tax collections should also achieve record levels, consistent with the strong performance seen when Gering previously hosted the Nationals from 2018 to 2022. Media coverage of hot air balloons flying over Scotts Bluff National Monument has been extraordinary, and these images continue to be used across local community websites.

Overall Economic Impact

Visitor Attendance Estimated based on previous years' attendance:

- 5,600 out-of-town visitors (including Eastern Nebraska)
- 4,400 in-state visitors (within a 100-mile radius of the event)
- Total attendance: 10,000+
- Average stay for out-of-town visitors: 2 nights

Direct Visitor Spending

Using the State of Nebraska's Tourism spending figures for our rural area. Out-of-town guests spend on average \$120 - \$150 per day at local restaurants, hotels, and retail establishments.

Based on 2025 tourism figures, we anticipate 5,600 out-of-town guests will visit the event. Using that figure, we can estimate the following:

The low estimate: 5,600 visitors times **\$120 = \$672,000** per day

The High estimate: 5,600 visitors times **\$150 = \$840,000** per day

Most out-of-town guests visiting our event average a two-night stay, which amounts to the following spending trend:

Out-of-town Visitor Spending two days, low estimate = **\$1,344,000.00**

Out-of-town Visitor Spending two days, high estimate = **\$1,680,000.00**

In-State Visitors (within a 100-mile radius of the event)

Based on 2025 tourism figures, we anticipate a total of 4,400 regional and local guests visiting the event. Using that figure, we can estimate the following:

The low estimate: 4,400 visitors times \$65 = **\$286,000** per day

The High estimate: 4,400 visitors times \$85 = **\$374,000** per day

Adding up the spending from local, regional, and out-of-state visitors, we estimate the following spending totals:

Total Visitor Spending low estimate = **\$1,630,000.00**

Total Visitor Spending high estimate = **\$2,054,000.00**

This figure does not include lodging and sales tax

Lodging Impact

Approximately 810 rooms are available in Scotts Bluff County for booking in 2026 for the event, at an average rate of \$150.00 per night. These figures do not include RV spots or Airbnb/VRBO rentals.

810 rooms x 7 nights booked for Nationals at an average cost of \$150 per night =
\$850,500.00

Lodging tax collected at 3%:

810 rooms x \$150 x 7 nights = \$850,500.00

3% lodging tax collected = \$25,515.00

Tax Revenue Generated on spending projections of 1.6 - 2.0 million in sales, based on 6% tax rate:

Estimated Local Tax Revenue

\$96,000–\$120,000

These funds support local infrastructure, public safety, and community services.

Total Direct Economic Impact

The total direct economic impact, with adding tax revenue to spending projections, is estimated at

\$1.7 – \$2.1 million, which benefits local businesses and communities in Scotts Bluff County and surrounding areas.

Marketing

Our destination marketing efforts continue to demonstrate strong results. More than 45% of our 14,700 Facebook and website followers attend the event annually. These figures are based on Facebook analytics, reinforcing Scotts Bluff County's position as a regional vacation destination. Online parking pass sales further highlight our reach, with purchases coming from 26 U.S. states, as well as the United Kingdom, Mexico, and Canada. In addition, 46 of Nebraska's 93 counties were represented. This broad geographic distribution reflects the effectiveness of our comprehensive and targeted marketing campaign.

The event will be advertised through newspapers, local television, statewide social media, National media, the official program, and Rural Radio, reaching all communities in the Panhandle of Western Nebraska, Eastern Nebraska, Eastern Wyoming, Southern South Dakota, and Northern Colorado, including the Front Range, and National exposure through the program *My Town*.

We are committed to marketing the 2026 event and have set aside \$34,500.00 through in-kind donations and sponsorships to promote the Old West Balloon Fest.

Our extensive marketing program to promote the event includes:

- Nebraska Tourism Grant Program
- Rural Radio Ad Spots to run before the event on all major stations
- Advertisements in Inspire Magazine and Nebraska Life Magazine
- Social media blast on Visit Nebraska and banner ad that will run from May through August
- Social media boosted ads on our Facebook page starting in May

- Official program, which features participating balloons and sponsor thank-you advertisements.
- Our official website: theoldwestballoonfest.com
- Links on our website to tourism websites, sponsor websites, and visitor information.

While we have secured strong partnerships and continue to pursue sponsorships and grants, the financial responsibility associated with hosting a national championship exceeds the scope of our traditional budget. The additional support we are requesting will ensure that we can successfully deliver an event that meets national competition requirements, provides high-quality programming for residents and visitors, and continues to generate meaningful economic and cultural benefits for Scotts Bluff County.

The Old West Balloon Fest generates between \$1.6 and \$2.0 million in direct visitor spending, produces up to 5,650 hotel room night stays generating \$25,215 in lodging tax revenue, and contributes between \$96,000 and \$120,000 in sales tax revenue. These outcomes demonstrate the event's significant role in supporting economic development and community prosperity throughout Scotts Bluff County.

Agenda Item Summary

For the meeting of: May 11, 2026

Agenda item title: Consider moving the second regular City Council meeting in May to Tuesday, May 26 due to the Memorial Day holiday on Monday, May 25

Submitted by: Pat Heath, City Administrator

Explanation of the agenda item: Regular City Council meetings are held on the second and fourth Mondays of each month. The Memorial Day holiday falls on the fourth Monday of May this year.

Board/Commission/Staff recommendation: Staff recommend moving the May 25 regular Council meeting to May 26 in light of the holiday.

Does this item require the expenditure of funds? Yes X no

Are funds budgeted? Yes no

If no, comments: _____

Estimated Amount _____

Amount Budgeted _____

Department _____

Account _____

Account Description _____

Approval of funds available: _____

City Treasurer/Finance Director

Does this item require a resolution or an ordinance? yes X no

If a resolution or ordinance is required, it must be attached.

Approved for submittal: *Pat Heath, City Administrator*

Mayor, City Administrator or City Department Head

Referred to: _____ **Committee**

All Agenda Item Summaries and the required attachments are due by Noon on the Wednesday prior to the Council meeting. If the Wednesday prior to the City Council is a holiday, the deadline is Tuesday at Noon.

Agenda Item Summary

For the meeting of: May 11, 2026

Agenda item title: Consider Substation Transformer Bid – Electric Department

Submitted by: Annie Folck, City Engineer

Explanation of the agenda item:

As part of the ongoing voltage conversion project for the Electric Department, the City will be building a new substation in 2027. One of the key pieces of equipment for the substation is the electrical transformer. Transformer lead times are extremely long right now, so staff is ordering the transformer now in order to have it available in the Fall of 2027.

The transformer was publicly advertised and bid, and the City received four bids. The electrical engineers that are designing the substation evaluated the bids, taking into consideration efficiency to determine long-term comparative costs of the transformers. The low bid was from Uptegraff. After taking into consideration energy loss based on efficiency of the equipment, Uptegraff was still the lowest cost transformer. However, Uptegraff does not provide a fixed cost for the transformer; instead, there is a base cost and then they provide a Price Adjustment Procedure by which the final cost of the transformer will be determined at the time of shipment. This cost adjustment can be very significant. Additionally, the lead times on the Uptegraff transformer are much longer than the other transformers, and could push back the construction of the substation substantially.

For these reasons, the engineers have recommended going with the next lowest bid, which is a WEG transformer. Their bid is a fixed cost, excluding any tariffs that are enacted between now and when it ships. They had a much more favorable lead time, which would keep the project on track for Fall of 2027. Additionally, the transformer is the most efficient of the ones evaluated. The final purchase cost is \$1,284,293, not including sales tax. With sales tax, the total would be \$1,380,615. Of this cost, 20% of this would be due upon order, with progress payments to be made after that. It is estimated that approximately 40% of the cost would come out of the FY2026 budget, with the remainder to come out of the FY2027 budget.

Board/Commission/Staff recommendation: Staff recommends awarding the bid to WEG Transformers USA in the amount of \$1,284,293 (does not include sales tax).

Does this item require the expenditure of funds?	<u> X </u>	Yes	<u> </u>	no
---	--------------	------------	-------------------	-----------

Are funds budgeted?	<u> X </u>	Yes	<u> </u>	no
----------------------------	--------------	------------	-------------------	-----------

If no, comments:

Estimated Amount \$1,380,615 (including sales tax)- Estimated \$552,246 to be paid out of FY2026 with the remainder to be paid in FY2027

Amount Budgeted \$1,000,000

Department Electric

Account 201-06-6460

Account Description Capital Improvements

Approval of funds available: *Lyndsey Mathews, Finance Director*

City Treasurer/Finance Director

Approved for submittal: *Annie Folck, City Engineer*

Mayor, City Administrator or City Department Head



RVW INC.
4118 HOWARD BOULEVARD
P.O. BOX 495
COLUMBUS, NEBRASKA 68602-0495
402 564-2876 • FAX 402 563-3655

April 28, 2026

Management and City Council
City of Gering
1025 P Street, PO BOX 687
Gering, NE 69341

Subject: **Engineer's Recommendation Of Contract Award
10 MVA, 34.5 KV – 12.47/7.2 KV Three-Phase Substation Transformer**

Dear Ms. Folck and City Council:

On Tuesday, April 21, 2026, bids were received and opened for the purchase of a new 10 MVA, 34.5 KV Delta - 12.47/7.2 KV Grounded Wye, three-phase, transformer for use in the City's 21st Street Substation. There were four bidders and three of the bids were loss evaluated, i.e. dollar amounts assigned to the quoted guaranteed maximum losses to approximate the cost to operate the transformer over thirty years. This process is done so as to prevent the City from purchasing a low cost but high loss transformer that would end up costing more in the long run to operate. The fourth bid was thrown out because of lead time.

The low loss evaluated transformer bid was from Uptegraff out of Scottdale, PA, with a base bid of \$918,393 (price without sales tax). Uptegraff was both the low loss evaluated bidder and the low bidder overall (lowest cost and lowest guaranteed losses). However, concerns were raised about the lead time being over 80 weeks and later being changed to over 90 weeks. Uptegraff would not accept liquidated damages for possible further delays. There is also concern about the price index Uptegraff would impose at the time of delivery and not having a firm price as of now.

The next low loss evaluated transformer WEG Transformers USA out of Washington, MO, with a base bid of \$1,174,293 (price without sales tax). The difference between bids is \$275,900. This is reduced to around \$100,000 after a 30 year loss evaluation.

There were additional options considered during the evaluation. WEG is able to provide the freight, offloading (separate from freight), and testing/assembly for the transformer. Freight is estimated at \$60,000, offloading cost was estimated at \$20,000 and the testing/assembly cost was estimated at \$50,000. After discussions with the city, it was determined offloading could be done by a local company for a lower cost and was declined. The Doble Testing and Sweep Frequency Response Analysis are included in the testing/assembly. After these costs were adjusted, the final purchase cost of is **\$1,284,293 without sales tax or tariffs**. This cost does include freight.

The transformer does come with five (5) year extended warranty and in order to maintain this warranty. Maintenance will have to be completed according to the WEG's requirements and made available to WEG for review.

RVW has been involved with the purchase of multiple transformers WEG Transformers USA over the years and found them to be quality units. Thus, we are recommending award of the subject contract to WEG Transformers USA.

Attached for your information is a loss evaluated tabulation of the bids received for this transformer. WEG did take exception to multiple items in the contract. I have highlighted what I believe are the most important of these items. These are listed on the bottom of the bid evaluation tab. The detailed exceptions and clarifications are in the back of the contract should you need to review them.

If you have any questions, please let me know.

Sincerely,
RVW, Inc.

A handwritten signature in black ink that reads "Brian Stepanek". The signature is written in a cursive style with a large initial "B".

Brian Stepanek, E.I.T.
Electrical Engineer

Attachment

cc: File E25-140

CITY OF GERING - 21st STREET SUB TRANSFORMER

SUBSTATION TRANSFORMER BID TABULATION AND EVALUATION

Proposal 1 - 10 MVA, 34.5 KV - 12.47/7.2 KV, Substation Transformer
 Tabulation of Bids: April 21st

Representative Manufacturer	Resco Virginia	Uptegraff	Mochn Electric Sales WEG Transformer	Niagara
Contract Cost (Total Bid w/o Tax)	\$1,230,500.00	\$918,393.00	\$1,174,293.00	\$1,307,465.00
Sweep Frequency Test (Optional)	\$10,500.00	\$5,000.00	Included with Assembly	No Evaluation
Cost To Doble Test Transformer On-Site (Optional)	\$6,500.00	\$3,000.00	Included with Assembly	No Evaluation
Offloading (Optional)	\$32,471.00	Not Included, No Price given	\$20,000.00	No Evaluation
Cost To assemble Transformer	\$80,000.00	Included	\$50,000.00	No Evaluation
Shipping	\$35,000.00	Included	\$60,000.00	No Evaluation
Total	\$1,394,971.00	\$926,393.00	\$1,304,293.00	No Evaluation

Base Unit Bid	\$1,230,500.00	\$918,393.00	\$1,174,293.00	\$0.00
Number of Units	1	1	1	0
No Load Loss (KW)	7.2	8.5	9	0
Load Loss (KW)	47.5	65	35	0
Loss Evaluated Unit Bid	\$1,545,750.00	\$1,339,643.00	\$1,434,293.00	\$0.00

@ \$7500/KW No Load Loss and
 \$5500/KW of Load Loss

Delivery (Weeks)	50-55	82-84 → 90-92	68-71	156
App. Drawing Submittal (Weeks)	18-20	52	17	40

Items Shipped Unassembled	Bushings and Arrestors	Bushings and Arrestors	Bushings and Arrestors
Exceptions/Notes:	VTC reserves right to invoice additional cost surcharges due to increases in service charges, wages, parts and commodities	Price Adjustment Procedure -Material cost is adjusted at time of manufacture	
	Payment terms, 10% upon shipment, 90% upon Delivery, Net 30 Days	Pay Schedule 20% upon order 30% drawings 50% manufactured completion	Pay Schedule 20% upon order 20% drawings 40% manufactured completion 10% delivery
		Shipping is subject to change based on factory loading at time of order	
	Accept LD's 500 per day max 5%	Will not accept liquidated damages	Accept LD's 1000 per day max 5%
	Warranty 60/60 months. Requires yearly DGA reports to VT. Only covers direct costs.	Warranty 66/60 months. Repair, replacement, and freight only. No removal, reinstallation, or incidental	Warranty 66/60 months
	Tarrifs are not included seller will absorb up to 2%	Buyer is responsible for Tarrifs	Tarrifs are not included or will be charged when they are occurred